

Dätwyler Cables

Cable technology for highest safety requirements



Daetwyler

Daetwyler Cables

We are a provider of high-grade quality system solutions and services in the areas of structured data cabling, telecom carriers, safety cabling, building automation, cabling for the elevator industry, as well as for cable harnessing.

We are a market leader in many areas with our innovative and high-performing products and system solutions.

We achieve revenues of approximately 180 million Euros deploying around 780 staff members.

Daetwyler Group

The Daetwyler Group is an internationally-oriented multiniche player, active as an industrial supplier and distributor of technical and electronic components. Within these activities, the group focuses on attractive markets and niches with a potential for increasing its added value and achieving profitable growth. Through its four group divisions - Cables, Rubber, Pharmaceutical Packaging and Technical Components - the Daetwyler Group serves its core markets for the automotive, telecom and pharmaceutical as well as the construction and machine manufacturing industries.

The Daetwyler Group, based in Altdorf (Switzerland), employs 4 400 staff and has sales of approximately 800 million Euros; two thirds of which is achieved abroad.

Innovation and Tradition

- 
- | | | | |
|------|--|------|--|
| 1915 | Adolf Dätwyler establishes the company, and launches the production of electric cables made of aluminum. | 1987 | Introduction of uninet® data copper cables, and the future-oriented conception of the structured data cabling. |
| 1926 | The manufacture of telephone cables is launched. | 1991 | pyrofil® safety cables are successfully certified for E90 in accordance with DIN 4102-12 for the first time |
| 1944 | The manufacture of high-frequency cables is launched. | 1992 | Establishment of Dätwyler System und Netzwerk GmbH headquartered in Neufahrn near Munich, Germany, worldwide. |
| 1945 | For the first time in the history of high-voltage cables, Dätwyler isolates power cables accommodating over 15 kV capacity by using polyethylene material. | 1995 | Merger of both German subsidiaries to the company Dätwyler Kabel+Systeme GmbH. |
| 1956 | Manufacturing start-up of transmitter and receiver cables for televisions. | 1996 | Establishment of Dätwyler Kabel+Systeme GmbH head-quartered in Vienna, Austria. |
| 1975 | The flameproof cable "Pyrofil250" is well accepted by the market. | 1997 | Establishment of Dätwyler Cables+Systems Pte Ltd., Singapore. |
| 1977 | "IXOSIL" end pieces supplement our high-voltage cable product line accommodating up to 60 kV capacity. | 1998 | Establishment of Datwyler Cables+Systems Co. Ltd Shanghai, China. |
| 1980 | Establishment of Dätwyler Elektro GmbH headquartered in Hattersheim near Frankfurt, Germany. | 2000 | Dätwyler AG Altdorf sells the business area for high-voltage technology to Alcatel Cable Suisse SA. |
| 1981 | The manufacture of high-voltage cables with built-in fibre optic represents a novelty on a worldwide basis. | 2002 | optofil® Safety is the first metalfree fibre optic cable with circuit integrity E30 according to DIN 4102-12. |
| 1984 | Establishment of Dätwyler (UK) Ltd. | 2004 | Opening of the central EU-warehouse in Hattersheim near Frankfurt, Germany. |
| 1986 | Production start-up of fibre optic cables. As first-to-do manufacturer of cables. Dätwyler certifies halogen-free safety cables over a period of 90 minutes by employing the uniform temperature time curve. | 2005 | Dätwyler presents FloorLink, the economical wiring system for elevator shafts. |
| | | 2006 | Dun & Bradstreet Swiss Business Award 2005 for Dätwyler. |

Cable

Applications

Product range/Standards

Safety cables with system circuit integrity



Low voltage cables up to 0.6/1 kV
E30-E90; FE180; BS 6387 CWZ; PH30-120, Rf-1 1 1/2

Safety cables with insulation and circuit integrity to maintain power supplies to sprinkler systems, emergency lighting, smoke and heat extraction systems, emergency lift supplies and fire fighting lifts.

Single core cables from 1.5 to 630 mm²
Multi core cables from 1.5 to 300 mm²
Also available with mechanical protection

Standards/Approvals

IEC, EN, CENELEC, BS, DIN VDE, SEV, NBN, VKF, VdS, GOST-R, Ukraine

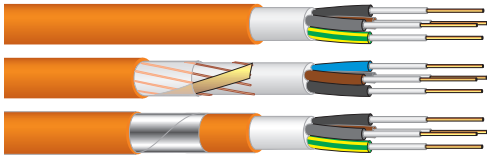

with mechanical protection

Safety cables with improved characteristics in case of fire



Low voltage cables up to 0.6/1 kV

Safety cables with improved characteristics in case of fire. The alternative to traditional PVC cables, where no insulation or circuit integrity is required.

Single core cables from 1.5 to 630 mm²
Multi core cables from 1.5 to 300 mm²
Also available with mechanical protection and as flexible version.

Standards/Approvals

IEC, EN, CENELEC, DIN VDE, SEV, GOST-R, Ukraine

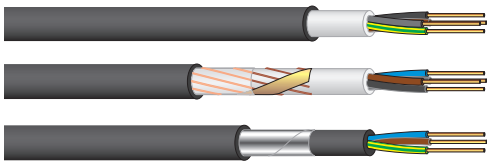

System components

Applications

Single clamps, multi cable supports



Single clamps to install single cables or cable bundles conforming to common practice.
Multiple cable supports for a cost effective installation of several cables.
These components facilitate the quick and easy installation of cables.

Support systems



Special support systems to install several cables conforming to common practice. Approved for ceiling and wall mounting with possibility of easy retrospective installation of cables.

Corresponding fixing devices, such as fire safety dowels, installation screws and setting tools are available for all support systems.

Connecting technology



Cable joints to connect pyrofil® safety cables with circuit integrity.

Distribution boxes with circuit integrity E30-E90. Also available as fire resistant covers to protect standard connection or junction blocks.
Distribution boxes with circuit integrity for high- and low-voltage cables.

The most important test procedures



Corrosive fire gases

This test procedure provides information if the insulation material of the sheath material of cable creates corrosive gases in the event of fire.

Halogen parts or other material in small quantities can be easily identified with this test due to the strong change of pH-value and the conductivity. The conductivity is < 10mS/mm

Corrosion test of fire gases

- IEC 60754-1/-2,
- EN 50267-2-1/-2-2,
- VDE 0482-267-2-1/-2-2

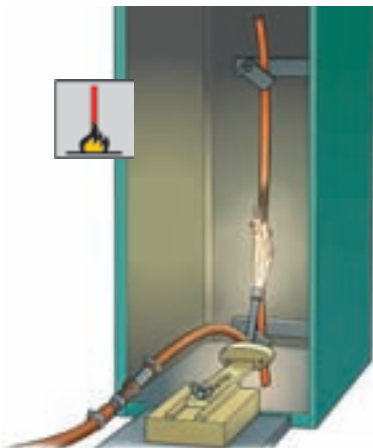

Burning behaviour of a single cable

This test method tests a 60 cm long cable sample for burning behaviour.

This means that the flame must extinguish itself and the burn damage must not reach the upper end of sample.

Test of Burning behaviour of a single tube or cable

- IEC 60332-1-1/-2,
- EN 60332-1-1/-2,
- VDE 0482-332-1-1/-2

Burning behaviour of a cable bundle

This test method tests a 360 cm long cable bundle with regard to fire propagation.

This means that flames must extinguish themselves and burn damage must not exceed a defined height.

Test of Burning behaviour of a cable bundle

- IEC 60332-3/-22/-23 /-24/-25 Cat. A-D
- EN 50266-2-2/-3/-4/-5 Cat. A-D
- VDE 0482-266-2-2/-3 /-4/-5 Cat. A-D

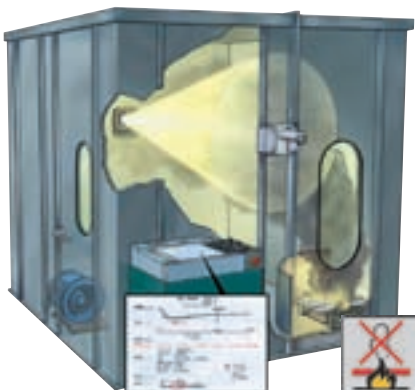

Smoke density test

This test checks smoke development when burning the cable or the impairment of the visibility by burning cables.

The reduction in light transparency is measured in a standard chamber.

Test of smoke density

- IEC 61034-1/-2,
- EN 61034-1/-2 (EN 50268-1/-2),
- VDE 0482-1034-1/-2
- (VDE 0482-268-1/-2)



Test of circuit integrity (FE)

This test establishes whether a single cable can maintain circuit integrity during and after exposure to a fire for a time period of at least 180 minutes. Cables which fulfil the requirements of this test are marked with <<FE180>> after their type designation.

There is no obligation to test the cable for functional integrity beyond the designated period.

Remark:

This test is not equivalent to the test for functional integrity according to DIN 4102-12

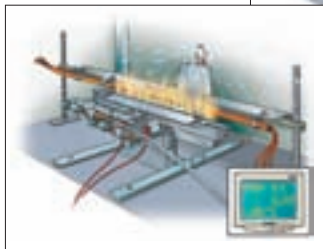
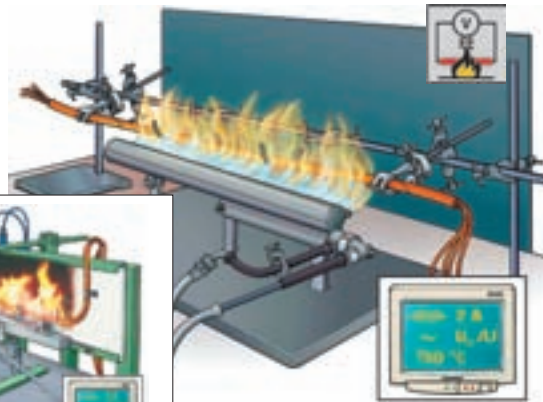

Test of Circuit integrity (Fire and water)

- BS 6387 (cat.W) [650°C]
- VdS 3423 [>830°C]

Test of Circuit integrity (Fire and mechanical shock)

- EN 50200, IEC 60331-2, VDE 0482-200 [>830°C]
- EN 50362, IEC 60331-1, VDE 0482-362 [>830°C]
- BS 6387 (cat.Z) [950°C]

Test of Circuit integrity (Fire alone)

- IEC 60331-11/-21/-23 /-25 [>750°C]
- BS 6387 (cat. C) [950°C]
- VDE 0472-814 [>750°C]

Test of Circuit integrity of electrical cable installations

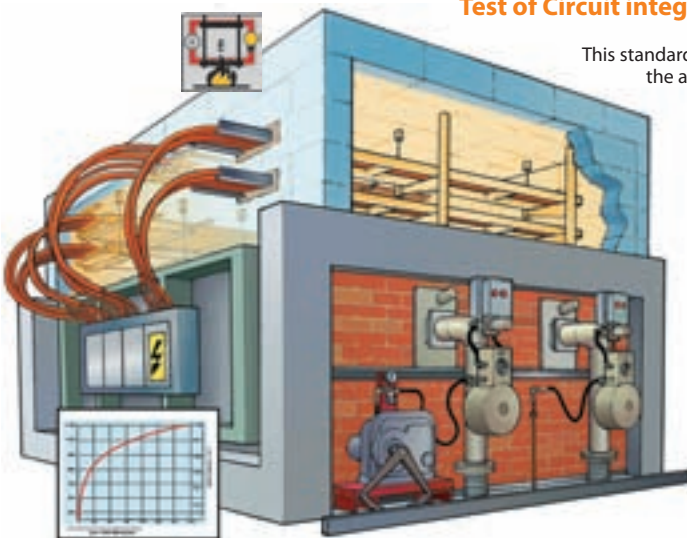

This standard describes the requirements and the actions for the achievement of the functional integrity of electrical cable installations in the event of fire.

While the "circuit integrity FE" provides only for the test of single cables, the cables here are tested in connection with practical fixing systems.

It is important to appreciate that there is no connection between the two standards, circuit integrity (FE/PH) and system circuit integrity (E).

The test is carried out and certified from state recognised institutes.

Test of circuit integrity of electrical cable installations

- DIN 4102-12 (E30-E90)
- (NBN 713.020 (Rf1, Rf1 1/2))

Better than the standard!

This test (E30-E90) is now the world wide standard for guaranteeing functional integrity of the complete electrical cable installation, including the fixing components, under normal operating conditions.

pyrofil® N2XH

Safety low voltage cable 0.6/1kV

Halogen-free, with improved fire characteristics
CENELEC HD 604 S1, VDE 0276-604

Dätwyler Cables

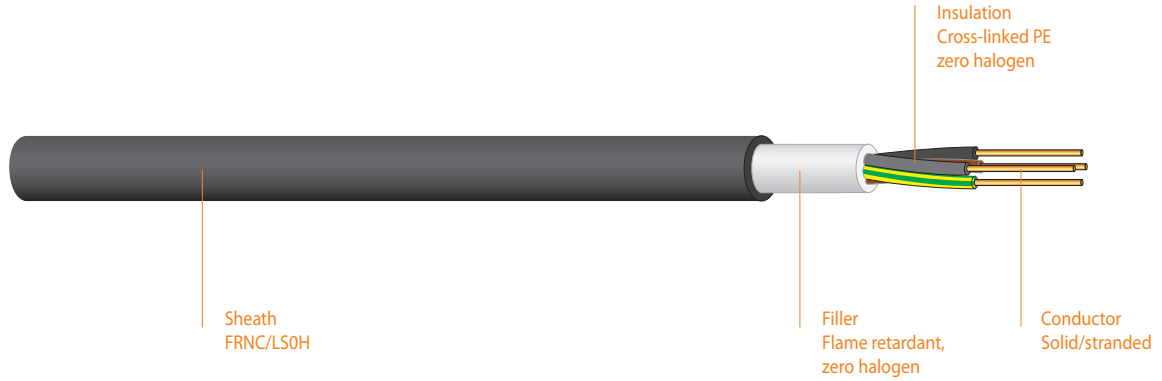

Product information

Application

For permanent installation in dry, damp or wet areas, on or behind plasterwork or in walls or concrete. Also suitable for outdoor applications. The cable should only be laid directly in earth or water if a protective conduit is used. Permitted operating temperature at conductor of +90°C.

Construction

Conductor	Bare copper, solid or stranded to IEC 60228, EN 60228, (VDE 0295)
Insulation	Cross-linked polyethylene in according to CENELEC HD 604 S1 and VDE 0276-604 "2X11"
Filler	Halogenfree, compound or plastic tape
Outer sheath	Polyolefin compound in according to CENELEC HD 604 S1 and VDE 0276-604 "HM4"
Core colours	According to CENELEC HD 308 S2 and VDE 0293
Sheath colour	Black or green/yellow
Imprint	DAETWYLER PYROFIL N2XH 1kV "N X MM2" <VDE> 0276 "ORDER NO." "YEAR" "METRE MARKING"

Electrical Properties

Nominal voltage	0.6/1kV
Test voltage	4000V, 50Hz

General Properties

Minimum bending Radius	during and permanent installation 15* x D (single core cable) 12* x D (multicore cable) (D = outer diameter)
Operating temperature	permanent installation -45°C to +90°C during installation -5°C to +50°C

- Zero halogen non corrosive gases
IEC 60754-2, EN 50267-2-2, VDE 0482-267-2-2
- Flame retardant
IEC 60332-1-2, EN 60332-1-2, VDE 0482-332-1-2
- Fire resistant (no flame propagation)
IEC 60332-3-22/-24 Cat. A/C, EN 50266-2-2/-4 Cat. A/C,
VDE 0482-266-2-2/-4 Cat. A/C
- Minimum smoke emission
IEC 61034-1/-2, EN 61034-1/-2 (EN 50268-1/-2),
VDE 0482-1034-1/-2 (VDE 0482-268-1/-2)

Article No.	No. of cores x cross section n x mm²	Colours	Cu content kg/km	Total weight app. kg/km	Mean overall diameter app. in mm
170 014	1 x 16 RM	green/yellow	154	202	9,1
170 004	1 x 25 RM	black	240	302	11,0
170 005	1 x 25 RM	green/yellow	240	302	11,0
170 010	1 x 35 RM	black	336	397	12,0
170 026	1 x 35 RM	green/yellow	336	397	12,0
170 006	1 x 50 RM	black	480	523	13,0
170 007	1 x 50 RM	green/yellow	480	523	13,0
170 018	1 x 70 RM	black	672	745	15,0
170 030	1 x 70 RM	green/yellow	672	745	15,0
170 008	1 x 95 RM	black	912	986	17,0
170 009	1 x 95 RM	green/yellow	912	986	17,0
170 019	1 x120 RM	black	1152	1214	18,0
170 025	1 x120 RM	green/yellow	1152	1214	18,0
170 020	1 x150 RM	black	1440	1536	21,0
191 566	1 x150 RM	green/yellow	1440	1536	21,0
170 011	1 x185 RM	black	1776	1888	23,0
170 031	1 x185 RM	green/yellow	1776	1888	23,0
170 012	1 x240 RM	black	2304	2472	26,0
170 016	1 x240 RM	green/yellow	2304	2472	26,0
190 524	2 x 1,5 RE		29	120	8,0
188 201	3 x 1,5 RE		43	135	9,0
188 204	3 x 2,5 RE		72	181	10,0
188 349	3 x 4 RE		115	242	11,0
188 210	3 x 6 RE		173	319	12,5
190 505	3 x 10 RE		288	464	14,0
188 216	3 x 16 RM		461	697	17,0
188 202	4 x 1,5 RE		58	163	10,0
188 205	4 x 2,5 RE		96	214	11,0
188 208	4 x 4 RE		154	294	12,0
188 211	4 x 6 RE		230	390	14,0
188 214	4 x 10 RE		384	586	16,0
188 217	4 x 16 RM		614	874	19,0
188 219	4 x 25 RM		960	1332	23,0
188 028	4 x 35 RM		1344	1777	26,0
188 222	4 x 50 RM		1920	2343	29,0
188 030	4 x 70 RM		2688	3384	35,0
188 224	4 x 95 RM		3648	4490	39,0
188 203	5 x 1,5 RE		72	193	11,0
188 206	5 x 2,5 RE		120	256	12,0
188 357	5 x 4 RE		192	352	13,0
188 358	5 x 6 RE		288	475	15,0
188 215	5 x 10 RE		480	708	17,0
188 218	5 x 16 RM		768	1081	21,0
188 220	5 x 25 RM		1200	1631	25,5
170 095	7 x 1,5 RE		101	230	12,0
170 096	7 x 2,5 RE		168	315	13,0
170 104	10 x 1,5 RE		144	326	15,0
170 105	10 x 2,5 RE		240	447	16,0
170 099	12 x 1,5 RE		173	365	15,0
170 106	12 x 2,5 RE		288	510	17,0
170 107	14 x 1,5 RE		202	420	16,0
170 100	19 x 1,5 RE		274	511	18,0
170 101	24 x 1,5 RE		346	664	21,0
170 108	30 x 1,5 RE		432	793	22,0

RE= circular, solid conductor
RM= circular, stranded conductor
Additional dimensions available on request.

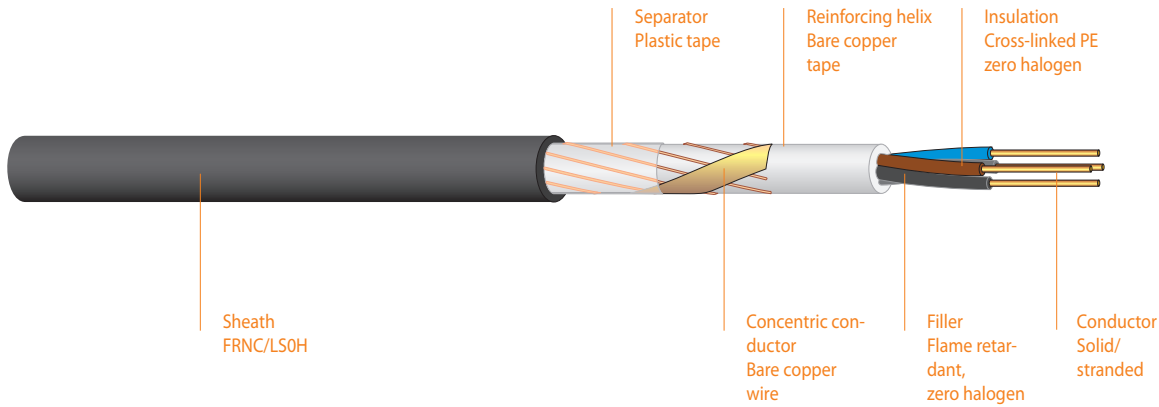

Application

For permanent installation in dry, damp or wet areas, on or behind plasterwork or in walls or concrete. Also suitable for outdoor applications. The cable should only be laid directly in earth or water if a protective conduit is used.

Permitted operating temperature at conductor of +90°C.

Construction

Conductor	Bare copper, solid or stranded to IEC 60228, EN 60228, (VDE 0295)
Insulation	Cross-linked polyethylene in according to CENELEC HD 604 S1 and VDE 0276-604 "2X11"
Filler	Halogenfree, compound or plastic tape
Concentric conductor	Bare copper wires with reinforced helix
Separator	Plastic tape
Outer sheath	Polyolefin compound in according to CENELEC HD 604 S1 and VDE 0276-604 "HM4"
Core colours	According to CENELEC HD 308 S2 and VDE 0293
Sheath colour	Black
Imprint	DAETWYLER PYROFIL N2XCH 1kV "N X MM2" <VDE> 0276 "ORDER NO." "YEAR" "METRE MARKING"

Electrical Properties

Nominal voltage	0.6/1kV
Test voltage	4000V, 50Hz

General Properties

Minimum bending Radius	during and permanent installation 12 x D (multicore cable) (D = outer diameter)
Operating temperature	permanent installation -45°C to +90°C during installation -5°C to +50°C

- Zero halogen non corrosive gases
IEC 60754-2, EN 50267-2-2, VDE 0482-267-2-2
- Flame retardant
IEC 60332-1-2, EN 60332-1-2, VDE 0482-332-1-2
- Fire resistant (no flame propagation)
IEC 60332-3-22/-24 Cat. A/C, EN 50266-2-2/-4 Cat. A/C, VDE 0482-266-2-2/-4 Cat. A/C
- Minimum smoke emission
IEC 61034-1/-2, EN 61034-1/-2 (EN 50268-1/-2), VDE 0482-1034-1/-2 (VDE 0482-268-1/-2)

Article No.	No. of cores x cross section n x mm ²	Cu content kg/km	Total weight app. kg/km	Mean overall diameter app. in mm
188 225	2 x 1,5 RE/1,5	52	162	11,0
188 228	2 x 2,5 RE/2,5	80	206	12,0
188 226	3 x 1,5 RE/1,5	66	180	11,0
188 229	3 x 2,5 RE/2,5	104	234	12,0
188 231	3 x 4 RE/4	161	319	14,0
188 233	3 x 6 RE/6	240	430	15,0
188 235	3 x 10 RE/10	408	611	17,0
188 237	3 x 16 RM/16	643	924	20,0
188 239	3 x 25 RM/16	902	1280	23,0
188 241	3 x 35 RM/16	1190	1634	26,0
188 243	3 x 50 RM/25	1723	2235	29,0
188 227	4 x 1,5 RE/1,5	81	205	12,0
188 230	4 x 2,5 RE/2,5	128	269	13,0
188 232	4 x 4 RE/4	200	375	15,0
188 234	4 x 6 RE/6	297	510	16,0
188 236	4 x 10 RE/10	504	745	18,0
188 238	4 x 16 RM/16	796	1107	21,0
188 240	4 x 25 RM/16	1142	1572	25,0
188 242	4 x 35 RM/16	1526	2013	28,0
188 244	4 x 50 RM/25	2203	2759	32,0
188 245	4 x 70 RM/35	3082	3899	38,0
188 246	4 x 95 RM/50	4208	5164	42,0
188 247	4 x 120 RM/70	5388	6494	46,0
188 248	4 x 150 RM/70	6540	7959	52,0
188 249	4 x 185 RM/95	8159	9932	57,0
188 250	4 x 240 RM/120	10546	12989	65,0
170 156	7 x 1,5 RE/2,5	133	286	14,0
170 191	7 x 2,5 RE/2,5	200	373	15,0
170 192	7 x 4 RE/4	315	532	17,0
170 193	7 x 6 RE/6	470	727	18,0
170 157	12 x 1,5 RE/2,5	205	429	17,0
170 195	12 x 2,5 RE/4	334	600	19,0
170 158	24 x 1,5 RE/6	413	790	23,0
170 159	30 x 1,5 RE/6	499	921	25,0
170 196	30 x 2,5 RE/10	840	1319	28,0

170 157	12 x 1,5 RE/2,5	205	429	17,0
170 195	12 x 2,5 RE/4	334	600	19,0
170 158	24 x 1,5 RE/6	413	790	23,0
170 159	30 x 1,5 RE/6	499	921	25,0
170 196	30 x 2,5 RE/10	840	1319	28,0

RE= circular, solid conductor
RM= circular, stranded conductor
Additional dimensions available on request.

pyrofil® FE5-CL

Safety low voltage cable 0.6/1kV

Armoured with rodent-protection

Halogen-free, with improved fire characteristics

With reference to SEV TP 20B/3C

and CENELEC HD 604 S1 part 5. H

Dätwyler Cables

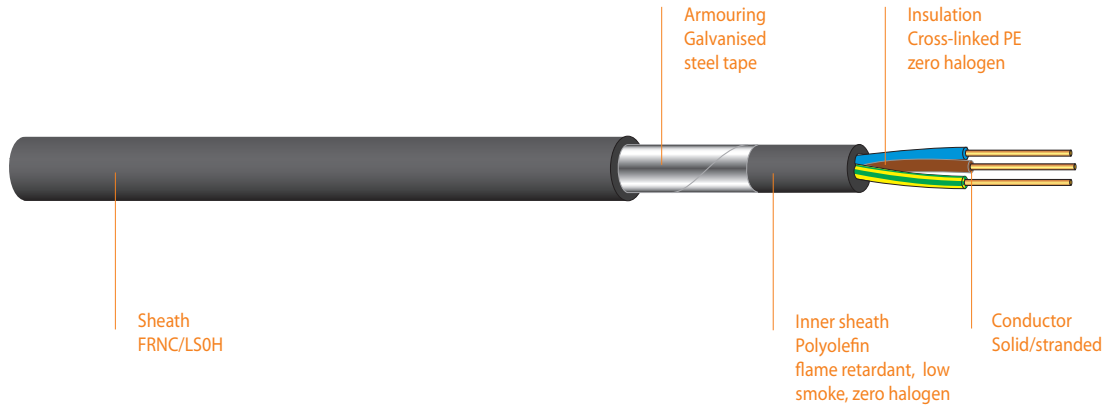

Product information

Application

For permanent installation in dry, damp or wet areas, on or behind plasterwork or in walls or concrete. Also suitable for outdoor applications. The cable should only be laid directly in earth or water if a protective conduit is used. Permitted operating temperature at conductor of +90°C.

Construction

Conductor	Bare copper, solid or stranded to IEC 60228, EN 60228
Insulation	Crosslinked polyethylene according to CENELEC HD 604 S1 part 5 sec. H "HIC"
Inner sheath	Flame retardant, Polyolefin compound according to CENELEC HD 604 S1 part 5 sec. H "HMT1"
Armouring / [rodent-protection]	Galvanised steel tape
Outer sheath	Flame retardant, Polyolefin compound according to CENELEC HD 604 S1 part 5 sec. H "HMT1"
Core colours	According to CENELEC HD 308 S2
Sheath colour	Black
Imprint	DAETWYLER PYROFIL CL "N X MM2" "ORDER NO." "YEAR" "METRE MARKING"

Electrical Properties

Nominal voltage	0.6/1kV
Test voltage	3500V, 50Hz

General Properties

Minimum bending Radius	during and permanent installation	
	15* x D (single core cable)	
	12* x D (multicore cable)	
	(D = outer diameter)	
Operating temperature	permanent installation	-45°C to +90°C
	during installation	-5°C to +50°C

- Zero halogen non corrosive gases
IEC 60754-2, EN 50267-2-2, VDE 0482-267-2-2, SEV TP 20B/3C 3.4.4
- Flame retardant
IEC 60332-1-2, EN 60332-1-2, VDE 0482-332-1-2, SEV TP 20B/3C 3.4.1.1
- Fire resistant (no flame propagation)
IEC 60332-3-24 Cat. C, EN 50266-2-4 Cat. C, VDE 0482-266-2-4 Cat. C, SEV TP 20B/3C 3.4.1.3
- Minimum smoke emission
IEC 61034-1/-2, EN 61034-1/-2 (EN 50268-1/-2), VDE 0482-1034-1/-2 (VDE 0482-268-1/-2), SEV TP 20B/3C 3.4.3

Article No.	No. of cores x cross section n x mm²	Cu content kg/km	Total weight app. kg/km	Mean overall diameter app. in mm
	2 x 1,5 RE	29	173	10
	2 x 2,5 RE	48	170	10
	3 x 1,5 RE	43	171	10
	3 x 2,5 RE	72	190	11
191 091	3 x 4 RE	115	240	12
	3 x 6 RE	173	350	14
	3 x 10 RE	288	515	16
	3 x 16 RM	461	770	20
	4 x 1,5 RE	58	189	10
	4 x 2,5 RE	96	220	11
	4 x 4 RE	154	305	13
	4 x 6 RE	230	420	15
	4 x 10 RE	384	630	17
	4 x 16 RM	614	1000	22
	4 x 25 RM	960	1450	26
	4 x 35 RM	1344	1950	30
191 064	5 x 2,5 RE	120	270	12
	5 x 4 RE	192	375	14
190 595	5 x 6 RE	288	510	16
188 389	5 x 10 RE	480	760	19
	5 x 10 RM	480	820	21
190 401	5 x 16 RM	768	1200	24
	5 x 25 RM	1200	1750	28
	5 x 35 RM	1680	2400	33
	5 x 50 RM	2400	3200	37
	5 x 70 RM	3360	4550	44
	5 x 95 RM	4560	6050	50
	7 x 1,5 RE	101	230	11
	7 x 2,5 RE	168	330	13
	7 x 4 RE	269	460	15
180 929	7 x 6 RE	403	651	17
184 531	7 x 10 RE	672	980	21
	8 x 1,5 RE	115	272	13
	8 x 2,5 RE	192	389	15
	10 x 1,5 RE	144	329	14
	10 x 2,5 RE	240	470	17
	12 x 1,5 RE	173	367	15
	12 x 2,5 RE	288	530	17
	21 x 2,5 RE	504	850	22
	27 x 2,5 RE	389	1050	24

RE= circular, solid conductor

RM= circular, stranded conductor

Additional dimensions available on request.

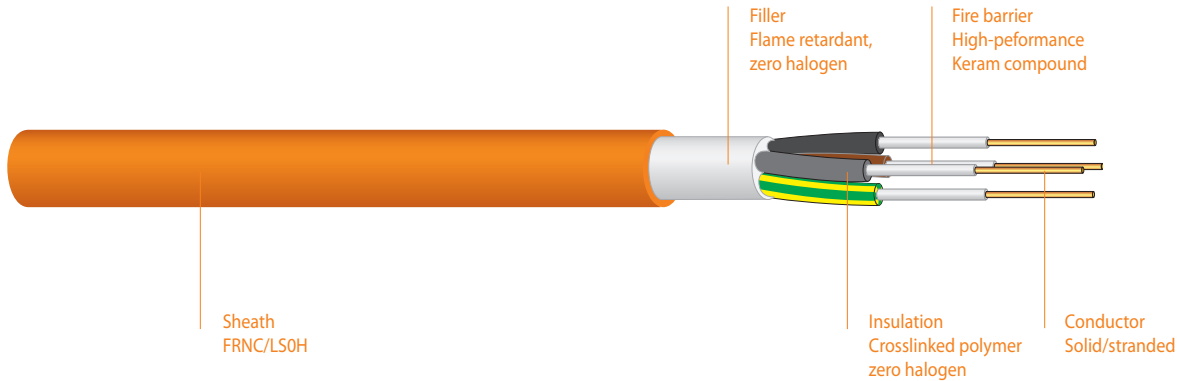

Application

Safety cables are used in all situations that require special protection against fire and flame damage for people and equipment and where a high degree of safety conditions must be fulfilled. Suitable for indoor applications. For outdoor applications, protection must be provided against exposure to direct sunlight. The cable should only be laid directly in earth or water if a protective conduit is used.
Permitted operating temperature at conductor +90°C.

Construction

Conductor Bare copper, solid or stranded to IEC 60228, EN 60228, (VDE 0295)
Insulation Double insulation, cross-linked, high-performance Keram special compound according to CENELEC HD 604 S1 part 5 sec. H "HIC"
Filler Flame retardant, halogenfree, thermoplastic compound
Outer sheath Flame retardant, Polyolefin compound according to CENELEC HD 604 S1 part 5 sec. H "HMT1"
Core colours According to CENELEC HD 308 S2
Sheath colour orange
Imprint DAETWYLER PYROFIL KERAM FE180 "N X MM2" "ORDER NO." "YEAR" "METRE MARKING"

Electrical Properties

Nominal voltage 0.6/1kV
Test voltage 3500V, 50Hz

General Properties

Minimum bending Radius during and permanent installation
15* x D (single core cable)
12* x D (multicore cable)
(D = outer diameter)
permanent installation
*50% reduction if installation at 30°C and with a template
Operating temperature permanent installation -45°C to +90°C
during installation -5°C to +50°C

- Zero halogen non corrosive gases
IEC 60754-2, EN 50267-2-2, VDE 0482-267--2-2, SEV TP20B/3C 3.4.4
- Flame retardant
IEC 60332-1-2, EN 60332-1-2, VDE 0482-332-1-2, SEV TP20B/3C 3.4.1.1
- Fire resistant (no flame propagation)
IEC 60332-3-24 Cat. C, EN 50266-2-4 Cat. C, VDE 0482-266-2-4 Cat. C, SEV TP20B/3C 3.4.1.3
- Minimum smoke emission
IEC 61034-1/-2, EN 61034-1/-2 (EN 50268-1/-2), VDE 0482-1034-1/-2 (VDE 0482-268-1/-2), SEV TP20B/3C 3.4.3
- Circuit integrity (FE180)
IEC 60331-11/-21 (180 minutes), VDE 0472 part 814, SEV TP20B/3C 3.4.2

Article No.	No. of cores x cross section n x mm²	Cu content kg/km	Total weight app. kg/km	Mean overall diameter app. in mm
171 370	1 x 16 RM	227	9,8	
171 377	1 x 25 RM	240	329	11,3
171 386	1 x 35 RM	336	428	12,4
171 394	1 x 50 RM	480	565	13,9
171 429	1 x 70 RM	672	783	15,7
170 842	1 x 95 RM	912	1054	18,1
170 845	1 x 120 RM	1152	1281	19,2
170 850	1 x 150 RM	1440	1606	21,4
170 855	1 x 185 RM	1776	1983	23,6
170 858	1 x 240 RM	2304	2607	26,8
188 360	2 x 1,5 RE	29	103	7,8
190 402	2 x 2,5 RE	48	144	9,0
	2 x 4 RE	77	202	10,4
	2 x 6 RE	115	272	11,8
	2 x 10 RE	192	407	14,0
186 952	2 x 16 RM	307	661	18,2
190 404	2 x 25 RM	480	950	21,2
187 180	3 x 1,5 RE	43	122	8,3
187 184	3 x 2,5 RE	72	171	9,5
187 187	3 x 4 RE	115	243	11,0
187 189	3 x 6 RE	173	333	12,5
	3 x 10 RE	288	502	14,8
186 953	3 x 16 RM	461	811	19,3
186 955	3 x 25 RM	720	1184	22,6
186 957	3 x 35 RM	1008	1529	24,9
186 959	3 x 50 RM	1440	2026	28,2
187 182	4 x 1,5 RE	58	148	9,1
	4 x 2,5 RE	96	212	10,5
	4 x 4 RE	154	304	12,2
	4 x 6 RE	230	414	13,8
	4 x 10 RE	384	635	16,4
186 967	4 x 16 RM	614	1009	21,1
186 968	4 x 25 RM	960	1485	24,8
186 969	4 x 35 RM	1344	1929	27,4
186 970	4 x 50 RM	1920	2600	31,5
186 971	4 x 70 RM	2688	3618	36,2
186 972	4 x 95 RM	3648	4860	41,7
186 973	4 x 120 RM	4608	5890	44,6
186 974	4 x 150 RM	5760	7417	50,0
187 548	4 x 185 RM	7104	9164	55,3
187 077	4 x 240 RM	9216	12029	63,0
187 183	5 x 1,5 RE	72	178	9,9
187 186	5 x 2,5 RE	120	261	11,6
187 188	5 x 4 RE	192	371	13,4
187 190	5 x 6 RE	288	509	15,2
	5 x 10 RE	480	777	18,1
186 975	5 x 16 RM	768	1223	23,1
186 976	5 x 25 RM	1200	1806	27,2
186 977	5 x 35 RM	1680	2384	30,5
186 978	5 x 50 RM	2400	3187	34,8
186 979	5 x 70 RM	3360	4440	40,0
190 587	5 x 95 RM	4560	6032	46,6
186 267	7 x 1,5 RE	101	222	10,8
186 268	7 x 2,5 RE	168	322	12,5
186 269	12 x 1,5 RE	173	365	14,2
	12 x 2,5 RE	288	541	16,7

RE= circular, solid conductor
RM= circular, stranded conductor
Additional dimensions available on request.

pyrofil® Keram FE180-CL

Safety low voltage cable 0.6/1kV, armoured with rodent-protection

Halogen-free, with improved fire characteristics
with reference to SEV TP 20B/3C and CENELEC HD 604 S1 part 5.H
Circuit integrity (FE180) in accordance IEC 60331

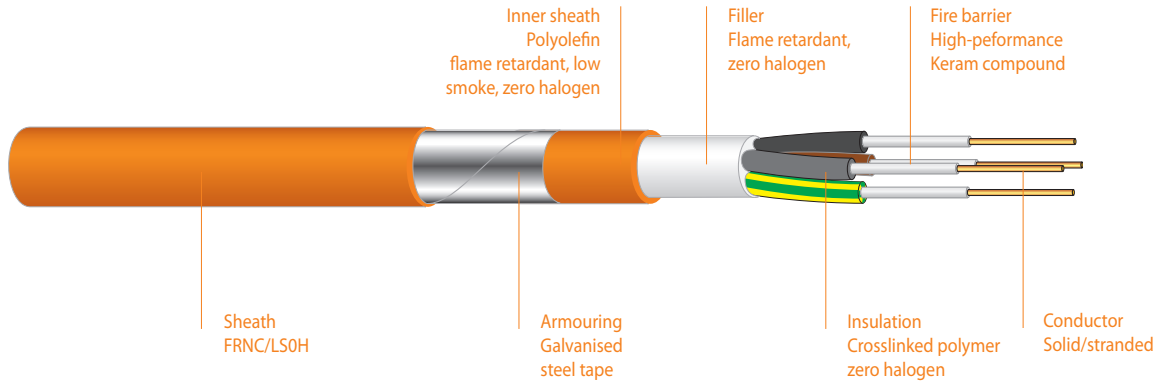

Product information

Application

Safety cables are used in all situations that require special protection against fire and flame damage for people and equipment and where a high degree of safety conditions must be fulfilled. Suitable for indoor applications. For outdoor applications, protection must be provided against exposure to direct sunlight. The cable should only be laid directly in earth or water if a protective conduit is used.
Permitted operating temperature at conductor +90°C.

Construction

Conductor	Bare copper, solid or stranded to IEC 60228, EN 60228
Insulation	Double insulation, cross-linked, high-performance Keram special compound according to CENELEC HD 604 S1 part 5 sec. H "HIC"
Filler	Flame retardant, halogenfree, thermoplastic compound
Inner sheath	Flame retardant, Polyolefin compound according to CENELEC HD 604 S1 part 5 sec. H "HMT1"
Armouring/ [rodent-protection]	Galvanised steel tape
Outer sheath	Flame retardant, Polyolefin compound according to CENELEC HD 604 S1 part 5 sec. H "HMT1"
Core colours	According to CENELEC HD 308 S2
Sheath colour	orange
Imprint	DAETWYLER PYROFIL KERAM FE180-CL "N X MM2""ORDER NO." "YEAR""METRE MARKING"

Electrical Properties

Nominal voltage	0.6/1kV
Test voltage	3500V, 50Hz

General Properties

Minimum bending Radius	during and permanent installation	
	15 x D (single core cable)	
	12 x D (multicore cable)	
	(D = outer diameter)	
Operating temperature	permanent installation	-45°C to +90°C
	during installation	-5°C to +50°C

- Zero halogen non corrosive gases
IEC 60754-2, EN 50267-2-2, VDE 0482-267--2-2,
SEV TP20B/3C 3.4.4
- Flame retardant
IEC 60332-1-2, EN 60332-1-2, VDE 0482-332-1-2,
SEV TP20B/3C 3.4.1.1
- Fire resistant (no flame propagation)
IEC 60332-3-24 Cat. C, EN 50266-2-4 Cat. C,
VDE 0482-266-2-4 Cat. C, SEV TP20B/3C 3.4.1.3
- Minimum smoke emission
IEC 61034-1/-2, EN 61034-1/-2 (EN 50268-1/-2),
VDE 0482-1034-1/-2 (VDE 0482-268-1/-2),
SEV TP20B/3C 3.4.3
- Circuit integrity (FE180)
IEC 60331-11/-21 (180 minutes), VDE 0472 part 814,
SEV TP20B/3C 3.4.2

Article No.	No. of cores x cross section n x mm ²	Cu content kg/km	Total weight app. kg/km	Mean overall diameter app. in mm
	3 x 1,5 RE 43 211	11		
187 199	3 x 2,5 RE	72	256	12
191 097	3 x 4,0 RE	115	373	14
191 121	3 x 6,0 RE	173	487	16
188 354	3 x 10 RE	288	656	18
188 327	3 x 16 RM	461	1075	24
	3 x 25 RM	720	1491	27
	3 x 35 RM	1008	1865	29
	3 x 50 RM	1440	2404	32
	3 x 70 RM	2016	3314	37
	3 x 95 RM	2736	4369	42
	3 x 120 RM	3456	5222	45
	3 x 150 RM	4320	6460	50
	4 x 1,5 RE	58	251	12
	4 x 2,5 RE	96	336	14
	4 x 4 RE	154	454	16
188 352	4 x 6 RE	230	538	17
	4 x 10 RE	384	872	21
186 980	4 x 16 RM	614	1296	25
186 981	4 x 25 RM	960	1820	29
186 982	4 x 35 RM	1344	2296	32
	4 x 50 RM	1920	3037	36
	4 x 70 RM	2688	4157	41
	4 x 95 RM	3648	5498	46
	4 x 120 RM	4608	6595	50
	4 x 150 RM	5760	8140	54
187 202	5 x 1,5 RE	72	260	12
191 038	5 x 2,5 RE	120	360	14
188 350	5 x 4 RE	192	489	16
188 353	5 x 6 RE	288	647	18
188 397	5 x 10 RE	480	971	21
187 154	5 x 16 RM	768	1536	27
186 984	5 x 25 RM	1200	2171	31
187 132	5 x 35 RM	1680	2808	35
187 131	5 x 50 RM	2400	3686	39
	5 x 70 RM	3360	5053	45
	5 x 95 RM	4560	6792	52
	7 x 1,5 RE	101	349	14
	7 x 2,5 RE	168	481	16
	7 x 4 RE	269	655	18
	7 x 6 RE	403	892	21
	7 x 10 RE	672	1335	25
	8 x 1,5 RE	115	411	16
	8 x 2,5 RE	192	561	18
	10 x 1,5 RE	144	498	18
	10 x 2,5 RE	240	677	20
	12 x 1,5 RE	173	546	18
	12 x 2,5 RE	288	781	21
	21 x 1,5 RE	303	849	22
	21 x 2,5 RE	504	1218	26
	27 x 1,5 RE	389	1075	25
	27 x 2,5 RE	648	1527	29

RE= circular, solid conductor
RM= circular, stranded conductor
Additional dimensions available on request.

Daetwyler Cables

pyrofil® Keram (N)HXH FE180 E30-E60

Safety low voltage cable 0.6/1kV

Halogen-free, with improved fire characteristics

With reference to VDE 0266 and CENELEC HD 604 S1

Circuit integrity (FE180) in accordance with VDE 0472-814, IEC 60331

System Circuit integrity E30-E60* in accordance with DIN 4102-12

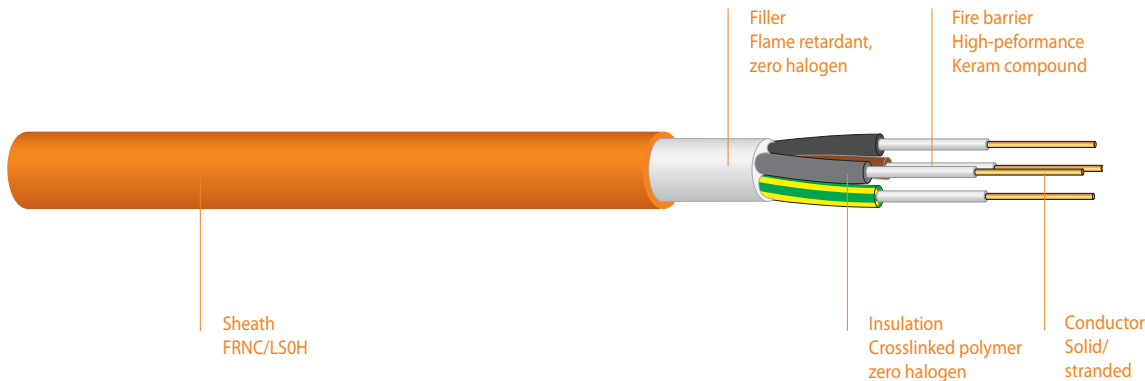

Application

Safety cables are used in all situations that require special protection against fire and flame damage for people and equipment and where a high degree of safety conditions must be fulfilled. Suitable for indoor applications. For outdoor applications, protection must be provided against exposure to direct sunlight.

The cable should only be laid directly in earth or water if a protective conduit is used. These cables correspond to the demands of system circuit integrity E30-E60* in accordance with DIN 4102-12. System circuit integrity is guaranteed at an operating voltage up to 400V. Permitted operating temperature at conductor +90°C.

Construction

Conductor	Bare copper, solid or stranded to IEC 60228, EN 60228, (VDE 0295)
Insulation	Double insulation, cross-linked, high-performance Keram special compound according to VDE 0266 "HX11"
Filler	Flame retardant, halogenfree, thermoplastic compound
Outer sheath	Flame retardant, Polyolefin compound according to CENELEC HD 604 S1 and VDE 0276-604 "HM4"
Core colours	According to CENELEC HD 308 S2 and VDE 0293
Sheath colour	orange
Imprint	DAETWYLER PYROFIL KERAM (N)HXH FE180 E30-E60 1kV "N X MM2" VDE REG. NR. 7780 "ORDER NO." "YEAR" "METRE MARKING"

Electrical Properties

Rated voltage	0.6/1kV
Test voltage	4000V, 50Hz

General Properties

Minimum bending Radius	during and permanent installation
	15* x D (single core cable)
	12* x D (multicore cable) (D = outer diameter)
	permanent installation
	*50% reduction if installation at 30°C and with a template
Operating temperature	permanent installation -45°C to +90°C
	during installation -5°C to +50°C

- Zero halogen non corrosive gases
IEC 60754-2, EN 50267-2-2, VDE 0482-267-2-2
- Flame retardant
IEC 60332-1-2, EN 60332-1-2, VDE 0482-332-1-2
- Fire resistant (no flame propagation)
IEC 60332-3-22/-24 Cat. A/C, EN 50266-2-2/-4 Cat. A/C, VDE 0482-266-2-2/-4 Cat. A/C
- Minimum smoke emission
IEC 61034-1/-2, EN 61034-1/-2 (EN 50268-1/-2), VDE 0482-1034-1/-2 (VDE 0482-268-1/-2)
- Circuit integrity (FE180)
IEC 60331-11/-21 (180 minutes), VDE 0472 part 814, BS 6387 CWZ, IEC 60331-2, EN 50200, VDE 0482-200 IEC 60331-1, EN 50362, VDE 0482-362
- System Circuit integrity E30-E60*
DIN 4102 part 12, NBN 713.020 (Rf1)

* System Circuit integrity is dependent on installation method.

Article No.	No. of cores x cross section n x mm ²	Cu content kg/km	Total weight app. kg/km	Mean overall diameter app. in mm
171 370	1 x 16 RM	154	227	9,8
171 377	1 x 25 RM	240	329	11,3
171 386	1 x 35 RM	336	428	12,4
171 394	1 x 50 RM	480	565	13,9
171 429	1 x 70 RM	672	783	15,7
170 842	1 x 95 RM	912	1054	18,1
170 845	1 x120 RM	1152	1279	19,2
170 850	1 x150 RM	1440	1604	21,4
170 855	1 x185 RM	1776	1981	23,6
170 858	1 x240 RM	2304	2604	26,8
186 280	2 x 1,5 RE	29	178	11,0
186 921	2 x 2,5 RE	48	217	11,8
186 922	2 x 4 RE	77	272	12,8
186 923	2 x 6 RE	115	337	13,8
186 924	2 x 10 RE	192	459	15,4
186 925	3 x 1,5 RE	43	200	11,5
186 926	3 x 2,5 RE	72	250	12,4
186 927	3 x 4 RE	115	319	13,5
186 928	3 x 6 RE	173	403	14,6
186 929	3 x 10 RE	288	560	16,3
186 953	3 x 16 RM	461	811	19,3
186 955	3 x 25 RM	720	1184	22,6
186 954	3 x 25 + 1 x 16 RM	874	1361	23,9
186 956	3 x 35 + 1 x 16 RM	1162	1692	25,9
186 958	3 x 50 + 1 x 25 RM	1680	2311	29,9
186 960	3 x 70 + 1 x 35 RM	2352	3171	34,0
186 962	3 x 95 + 1 x 50 RM	3216	4276	39,3
186 963	3 x 120 + 1 x 70 RM	4128	5303	42,6
186 964	3 x 150 + 1 x 70 RM	4992	6417	46,6
186 965	3 x 185 + 1 x 95 RM	6240	8040	52,0
186 930	4 x 1,5 RE	58	234	12,4
186 931	4 x 2,5 RE	96	296	13,4
186 932	4 x 4 RE	154	381	14,6
186 933	4 x 6 RE	230	490	15,8
186 934	4 x 10 RE	384	695	17,8
186 967	4 x 16 RM	614	1009	21,1
186 968	4 x 25 RM	960	1485	24,8
186 969	4 x 35 RM	1344	1929	27,4
186 970	4 x 50 RM	1920	2600	31,5
186 971	4 x 70 RM	2688	3618	36,2
186 972	4 x 95 RM	3648	4860	41,7
186 973	4 x120 RM	4608	5890	44,6
186 974	4 x150 RM	5760	7417	50,0
186 935	5 x 1,5 RE	72	278	13,4
186 936	5 x 2,5 RE	120	353	14,5
186 937	5 x 4 RE	192	456	15,8
186 938	5 x 6 RE	288	589	17,2
186 939	5 x 10 RE	480	832	19,3
186 975	5 x 16 RM	768	1223	23,1
186 976	5 x 25 RM	1200	1806	27,2
186 977	5 x 35 RM	1680	2384	30,5
186 978	5 x 50 RM	2400	3187	34,8
171 272	7 x 1,5 RE	101	331	14,4
171 273	7 x 2,5 RE	168	426	15,6
171 279	12 x 1,5 RE	173	513	18,3
171 280	12 x 2,5 RE	288	675	20,0
171 285	24 x 1,5 RE	346	901	24,6
171 286	24 x 2,5 RE	576	1205	27,0

RE= circular, solid conductor, RM= circular, stranded conductor

Additional dimensions available on request.

* Circuit integrity is dependent on installation method

pyrofil® Keram (N)HXCH FE180 E30-E60

Safety low voltage cable 0.6/1kV

Halogen-free, with improved fire characteristics

With reference to VDE 0266 and CENELEC HD 604 S1

Circuit integrity (FE180) in accordance with VDE 0472-814, IEC 60331

System Circuit integrity E30-E60* in accordance with DIN 4102-12

Dätwyler Cables

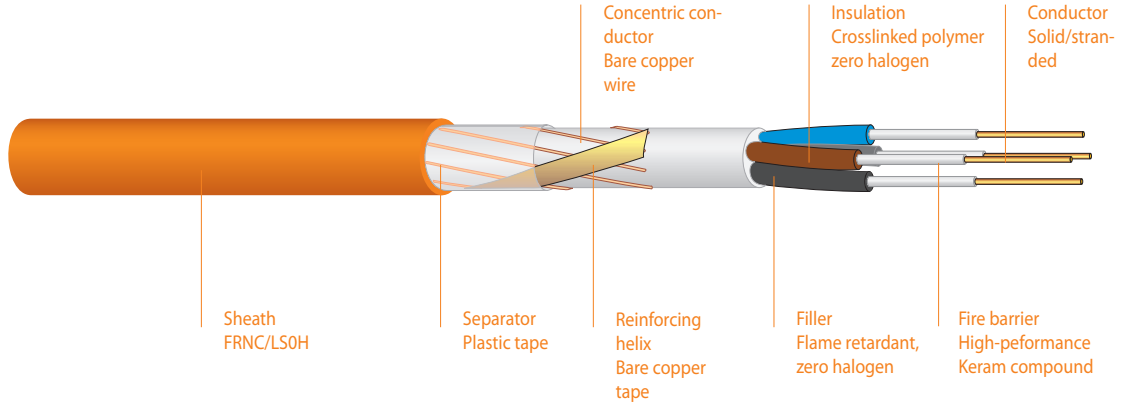

Product information

Application

Safety cables are used in all situations that require special protection against fire and flame damage for people and equipment and where a high degree of safety conditions must be fulfilled. Suitable for indoor applications. For outdoor applications, protection must be provided against exposure to direct sunlight. The cable should only be laid directly in earth or water if a protective conduit is used.

These cables correspond to the demands of system circuit integrity E30-E60* in accordance with DIN 4102-12. System circuit integrity is guaranteed at an operating voltage up to 400V. Permitted operating temperature at conductor +90°C.

Construction

Conductor	Bare copper, solid or stranded to IEC 60228, EN 60228, (VDE 0295)
Insulation	Double insulation, cross-linked, high-performance Keram special compound according to VDE 0266 "HX11"
Filler	Halogenfree, compound or plastic tape
Concentric conductor	Bare copper wires with reinforced helix
Separator	Plastic tape
Outer sheath	Polyolefin compound in accordance to CENELEC HD 604 S1 and VDE 0276-604 "HM4" according to CENELEC HD 308 S2 and VDE 0293
Core colours	orange
Sheath colour	orange
Imprint	DAETWYLER PYROFIL KERAM (N)HXCH FE180 E30-E60 1kV "N X MM2" VDE REG. NR. 7780 "ORDER NO. "YEAR" "METRE MARKING"

Electrical Properties

Nominal voltage	0.6/1kV
Test voltage	4000V, 50Hz

General Properties

Minimum bending Radius	during and permanent installation 15 x D (single core cable) 12 x D (multicore cable) (D = outer diameter)
Operating temperature	permanent installation -45°C to +90°C during installation -5°C to +50°C

- Zero halogen non corrosive gases
IEC 60754-2, EN 50267-2-2, VDE 0482-267-2-2
- Flame retardant
IEC 60332-1-2, EN 60332-1-2, VDE 0482-332-1-2
- Fire resistant (no flame propagation)
IEC 60332-3-22/-24 Cat. A/C, EN 50266-2-2/-4 Cat. A/C, VDE 0482-266-2-2/-4 Cat. A/C
- Minimum smoke emission
IEC 61034-1/-2, EN 61034-1/-2 (EN 50268-1/-2), VDE 0482-1034-1/-2 (VDE 0482-268-1/-2)
- Circuit integrity (FE180)
IEC 60331-11/-21 (180 minutes), VDE 0472 part 814, BS 6387 CWZ, IEC 60331-2, EN 50200, VDE 0482-200 IEC 60331-1, EN 50362, VDE 0482-362
- System Circuit integrity E30-E60*
DIN 4102 part 12

* System Circuit integrity is dependent on installation method.

Article No.	No. of cores x cross section n x mm²	Cu content kg/km	Total weight app. kg/km	Mean overall diameter app. in mm
186 943	2 x 1,5 RE/1,5	52	224	12,7
186 944	2 x 2,5 RE/2,5	80	273	13,5
187 232	2 x 4 RE/4	123	355	15,0
187 234	2 x 6 RE/6	182	436	16,0
187 236	2 x 10 RE/10	312	622	18,0
186 945	3 x 1,5 RE/1,5	66	248	13,2
186 946	3 x 2,5 RE/2,5	104	308	14,1
187 233	3 x 4 RE/4	161	404	15,7
187 235	3 x 6 RE/6	240	504	16,8
187 237	3 x 10 RE/10	408	727	18,9
187 238	3 x 16 RM/16	643	1148	23,9
187 239	3 x 25 RM/16	902	1437	25,0
187 240	3 x 35 RM/16	1190	1796	27,3
187 241	3 x 50 RM/25	1723	2408	30,8
187 242	3 x 70 RM/35	2410	3381	36,0
186 985	3 x 95 RM/50	3296	4513	41,1
186 986	3 x120 RM/70	4236	5576	44,5
186 987	3 x150 RM/70	5100	6799	49,2
187 243	3 x185 RM/95	6383	8300	56,0
186 988	3 x240 RM/120	8242	11065	61,5
186 947	4 x 1,5 RE/1,5	81	286	14,1
186 948	4 x 2,5 RE/2,5	128	358	15,1
186 949	4 x 4 RE/4	200	473	16,8
186 950	4 x 6 RE/6	297	621	18,1
186 951	4 x 10 RE/10	504	868	20,1
186 989	4 x 16 RM/16	796	1254	23,4
186 990	4 x 25 RM/16	1142	1752	27,2
186 991	4 x 35 RM/16	1526	2210	29,8
186 992	4 x 50 RM/25	2203	3049	34,8
186 993	4 x 70 RM/35	3082	4198	39,5
186 994	4 x 95 RM/50	4208	5600	45,2
186 995	4 x120 RM/70	5388	6940	49,1
186 996	4 x150 RM/70	6540	8500	54,3
186 997	4 x185 RM/95	8159	10615	59,8
186 998	4 x240 RM/120	10546	13830	67,9
187 244	7 x 1,5 RE/2,5	133	393	16,1
187 245	30 x 1,5 RE/6	499	1252	29,1

RE= circular, solid conductor, RM= circular, stranded conductor
Additional dimensions available on request. * Circuit integrity is dependent on installation method

Dätwyler Cables

pyrofil® Keram (N)HXH CL FE180 E30-E60
Safety low voltage cable 0.6/1kV armoured with rodent-protection
 Halogen-free, with improved fire characteristics
 With reference to VDE 0266 and CENELEC HD 604 S1
 Circuit integrity (FE180) in accordance with VDE 0472-814, IEC 60331
 System Circuit integrity E30-E60* in accordance with DIN 4102-12

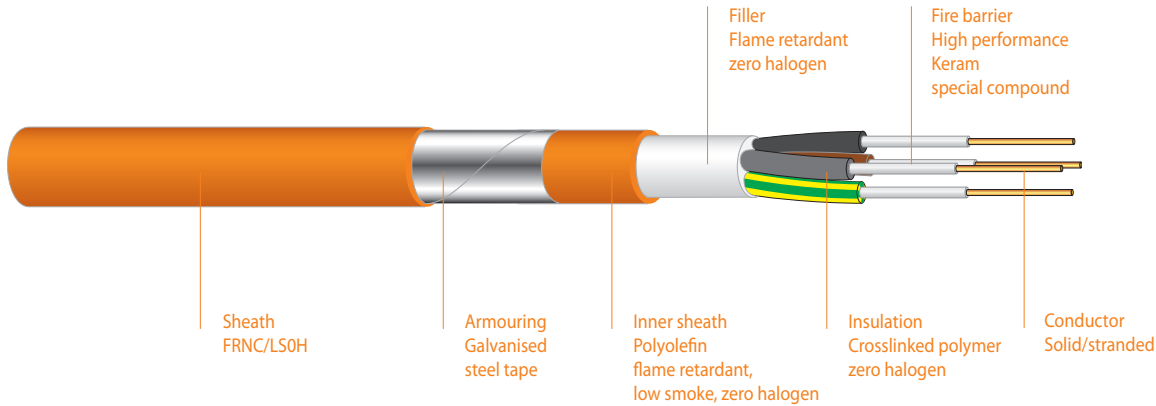

Product information

Application

Safety cables are used in all situations that require special protection against fire and flame damage for people and equipment and where a high degree of safety conditions must be fulfilled. Suitable for indoor applications. For outdoor applications, protection must be provided against exposure to direct sunlight. The cable should only be laid directly in earth or water if a protective conduit is used. These cables correspond to the demands of circuit integrity E30-E60* in accordance with DIN 4102-12. Circuit integrity is guaranteed at an operating voltage up to 400V. Permitted operating temperature at conductor +90°C.

Construction

Conductor	Bare copper, solid or stranded to IEC 60228, EN 60228, (VDE 0295)
Insulation	Double insulation, cross-linked, high-performance Keram special compound according to VDE 0266 "HX11"
Filler	Flame retardant, halogenfree, thermoplastic compound
Inner sheath	Flame retardant, Polyolefin compound according to CENELEC HD 604 S1 and VDE 0276-604 "HM4"
Armouring / [rodent-protection]	Galvanised steel tape
Outer sheath	Flame retardant, Polyolefin compound according to CENELEC HD 604 S1 and VDE 0276-604 "HM4"
Core colours	According to CENELEC HD 308 S2 and VDE 0293
Sheath colour	orange
Imprint	DAETWYLER PYROFIL KERAM (N)HXH CL FE180 E30-E60 1kV "N X MM2" VDE REG.NR. 7800 "ORDER NO." "YEAR" "METRE MARKING"

Electrical Properties

Nominal voltage	0.6/1kV
Test voltage	4000V, 50Hz

General Properties

Minimum bending Radius	during and permanent installation 15 x D (single core cable) 12 x D (multicore cable) (D = outer diameter)
Operating temperature	permanent installation -45°C to +90°C during installation -5°C to +50°C

- Zero halogen non corrosive gases
IEC 60754-2, EN 50267-2-2, VDE 0482-267-2-2
- Flame retardant
IEC 60332-1-2, EN 60332-1-2, VDE 0482-332-1-2
- Fire resistant (no flame propagation)
IEC 60332-3-22/-24 Cat. A/C, EN 50266-2-2/-4 Cat. A/C, VDE 0482-266-2-2/-4 Cat. A/C
- Minimum smoke emission
IEC 61034-1/-2, EN 61034-1/-2 (EN 50268-1/-2), VDE 0482-1034-1/-2 (VDE 0482-268-1/-2)
- Circuit integrity (FE180)
IEC 60331-11/-21 (180 minutes), VDE 0472 part 814, BS 6387 CWZ, IEC 60331-2, EN 50200, VDE 0482-200
- System Circuit integrity
DIN 4102 part 12 E30-E60*

* System Circuit integrity is dependent on installation method.

Article No.	No. of cores x cross section n x mm ²	Cu content kg/km	Total weight app. kg/km	Mean overall diameter app. in mm
	4 x 1,5 RE	58	410	17
190 590	4 x 2,5 RE	96	485	18
191 102	4 x 4 RE	154	585	19
	4 x 6 RE	230	710	20
	4 x 10 RE	384	940	22
186 980	4 x 16 RM	614	1296	25
186 981	4 x 25 RM	960	1820	29
186 982	4 x 35 RM	1344	2296	32
190 589	4 x 50 RM	1920	3037	36
	4 x 70 RM	2688	4157	41
	4 x 95 RM	3648	5498	47
	4 x 120 RM	4608	6595	50
	5 x 1,5 RE	72	466	18
188 117	5 x 2,5 RE	120	556	19
188 118	5 x 4 RE	192	676	20
186 941	5 x 6 RE	288	826	21
186 942	5 x 10 RE	480	1096	24
190 525	5 x 16 RM	768	1460	26
186 984	5 x 25 RM	1200	2171	31
190 529	5 x 35 RM	1680	2730	35
191 565	5 x 50 RM	2400	3620	39
	5 x 70 RM	3360	5054	45
	5 x 95 RM	4560	6792	52
185 232	7 x 1,5 RE	101	532	19
	7 x 2,5 RE	168	643	20
	12 x 1,5 RE	173	764	23
185 239	12 x 2,5 RE	288	873	23
185 235	30 x 1,5 RE	432	1407	30
185 241	30 x 2,5 RE	720	1848	33

RE= circular, solid conductor, RM= circular, stranded conductor
 Additional dimensions available on request.

* Circuit integrity is dependent on installation method

pyrofil® Keram (N)HXH FE180 E90

Safety low voltage cable 0.6/1kV

Halogen-free, with improved fire characteristics

With reference to VDE 0266 and CENELEC HD 604 S1

Circuit integrity (FE180) in accordance with VDE 0472-814, IEC 60331

System Circuit integrity E90 in accordance with DIN 4102-12

Dätwyler Cables

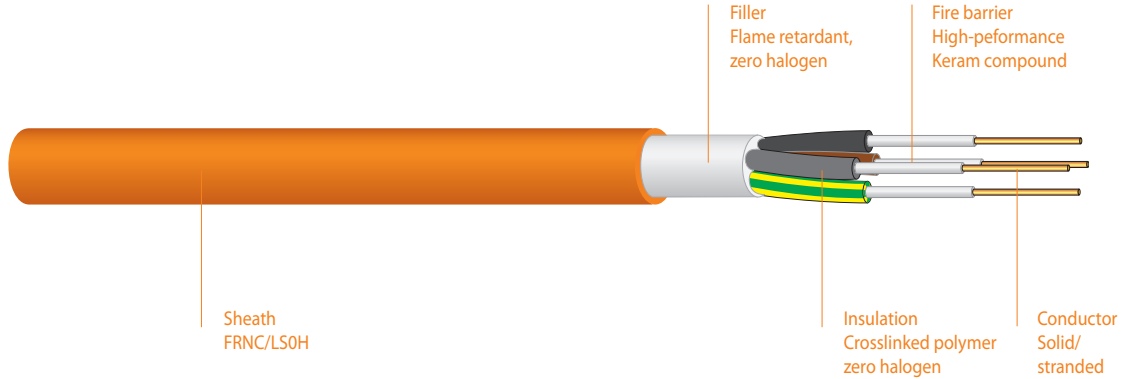

Product information

Application

Safety cables are used in all situations that require special protection against fire and flame damage for people and equipment and where a high degree of safety conditions must be fulfilled. Suitable for indoor applications. For outdoor applications, protection must be provided against exposure to direct sunlight. The cable should only be laid directly in earth or water if a protective conduit is used. These cables correspond to the demands of system circuit integrity E90 in accordance with DIN 4102-12. System circuit integrity is guaranteed at an operating voltage up to 400V. Permitted operating temperature at conductor +90°C.

Construction

Conductor Bare copper, solid or stranded to IEC 60228, EN 60228, (VDE 0295)
Insulation Double insulation, cross-linked, high-performance Keram special compound according to VDE 0266 "HX11"
Filler Flame retardant, halogenfree, thermoplastic compound
Outer sheath Flame retardant, Polyolefin compound according to CENELEC HD 604 S1 and VDE 0276-604 "HM4"
Core colours According to CENELEC HD 308 S2 and VDE 0293
Sheath colour orange
Imprint DAETWYLER PYROFIL KERAM (N)HXH FE180 E90 1kV "N X MM2" VDE REG. NR. 7780 "Vds" "ORDER NO." "YEAR" "METRE MARKING"

Electrical Properties

Nominal voltage 0.6/1kV
Test voltage 4000V, 50Hz

General Properties

Minimum bending Radius during and permanent installation
 15* x D (single core cable)
 12* x D (multicore cable) (D = outer diameter)
 permanent installation
 *50% reduction if installation at 30°C and with a template
Operating temperature permanent installation -45°C to +90°C
 during installation -5°C to +50°C

- Zero halogen non corrosive gases IEC 60754-2, EN 50267-2-2, VDE 0482-267-2-2
- Flame retardant IEC 60332-1-2, EN 60332-1-2, VDE 0482-332-1-2
- Fire resistant (no flame propagation) IEC 60332-3-22/-24 Cat. A/C, EN 50266-2-2/-4 Cat. A/C, VDE 0482-266-2-2/-4 Cat. A/C
- Minimum smoke emission IEC 61034-1/-2, EN 61034-1/-2 (EN 50268-1/-2), VDE 0482-1034-1/-2 (VDE 0482-268-1/-2)
- Circuit integrity (FE180) IEC 60331-11/-21 (180 minutes), VDE 0472 part 814, BS 6387 CWZ, IEC 60331-2, EN 50200, VDE 0482-200 IEC 60331-1, EN 50362, VDE 0482-362
- System Circuit integrity E90 DIN 4102 part 12 System Circuit integrity under effect of water Vds 3423 [single core cable ≥ 16mm²]

Article No.	No. of cores x cross section n x mm²	Cu content kg/km	Total weight app. kg/km	Mean overall diameter app. in mm
186 141	1 x 16 RM	154	243	10,2
186 142	1 x 25 RM	240	347	11,7
186 143	1 x 35 RM	336	449	12,8
186 144	1 x 50 RM	480	589	14,3
186 145	1 x 70 RM	672	810	16,1
186 146	1 x 95 RM	912	1090	18,5
186 147	1 x 120 RM	1152	1318	19,6
186 148	1 x 150 RM	1440	1648	21,8
186 149	1 x 185 RM	1776	2029	24,0
186 150	1 x 240 RM	2304	2658	27,2
187 246	2 x 1,5 RE	29	178	11,0
187 247	2 x 2,5 RE	48	217	11,8
187 248	2 x 4 RE	77	272	12,8
187 249	2 x 6 RE	115	337	13,8
187 250	2 x 10 RE	192	459	15,4
186 174	3 x 1,5 RE	43	200	11,5
186 177	3 x 2,5 RE	72	250	12,4
186 182	3 x 4 RE	115	319	13,5
186 186	3 x 6 RE	173	403	14,6
186 189	3 x 10 RE	288	560	16,3
186 152	3 x 16 RM	461	878	20,2
186 153	3 x 25 RM	720	1299	24,0
191 069	3 x 35 + 1 x 16 RM	1162	1833	27,4
191 002	3 x 50 + 1 x 25 RM	1680	2457	31,3
191 003	3 x 70 + 1 x 35 RM	2352	3362	35,6
191 004	3 x 95 + 1 x 50 RM	3216	4488	40,7
191 005	3 x 120 + 1 x 70 RM	4128	5532	44,0
191 006	3 x 150 + 1 x 70 RM	4992	6666	48,0
191 008	3 x 185 + 1 x 95 RM	6240	8315	53,4
186 175	4 x 1,5 RE	58	234	12,4
186 178	4 x 2,5 RE	96	296	13,4
186 183	4 x 4 RE	154	381	14,6
186 187	4 x 6 RE	230	490	15,8
186 190	4 x 10 RE	384	695	17,8
186 155	4 x 16 RM	614	1089	22,1
186 156	4 x 25 RM	960	1618	26,3
186 157	4 x 35 RM	1344	2083	29,0
186 158	4 x 50 RM	1920	2752	32,8
186 159	4 x 70 RM	2688	3804	37,6
186 160	4 x 95 RM	3648	5092	43,1
187 274	4 x 120 RM	4608	6133	46,0
186 161	4 x 150 RM	5760	7662	51,2
186 176	5 x 1,5 RE	72	278	13,4
186 179	5 x 2,5 RE	120	353	14,5
186 184	5 x 4 RE	192	456	15,8
186 188	5 x 6 RE	288	589	17,2
186 191	5 x 10 RE	480	832	19,3
186 162	5 x 16 RM	768	1361	24,8
186 163	5 x 25 RM	1200	1960	28,8
186 164	5 x 35 RM	1680	2547	32,0
186 165	5 x 50 RM	2400	3392	36,5
185 271	7 x 1,5 RE	101	331	14,4
186 180	7 x 2,5 RE	168	426	15,6
185 272	12 x 1,5 RE	173	513	18,3
186 181	12 x 2,5 RE	288	675	20,0
185 273	24 x 1,5 RE	346	901	24,6
187 230	24 x 2,5 RE	576	1210	27,0

RE= circular, solid conductor
 RM= circular, stranded conductor
 Additional dimensions available on request.

Dätwyler Cables

pyrofil® Keram (N)HXCH FE180 E90

Safety low voltage cable 0.6/1kV

Halogen-free, with improved fire characteristics

With reference to VDE 0266 and CENELEC HD 604 S1

Circuit integrity (FE180) in accordance with VDE 0472-814, IEC 60331

System Circuit integrity E90 in accordance with DIN 4102-12

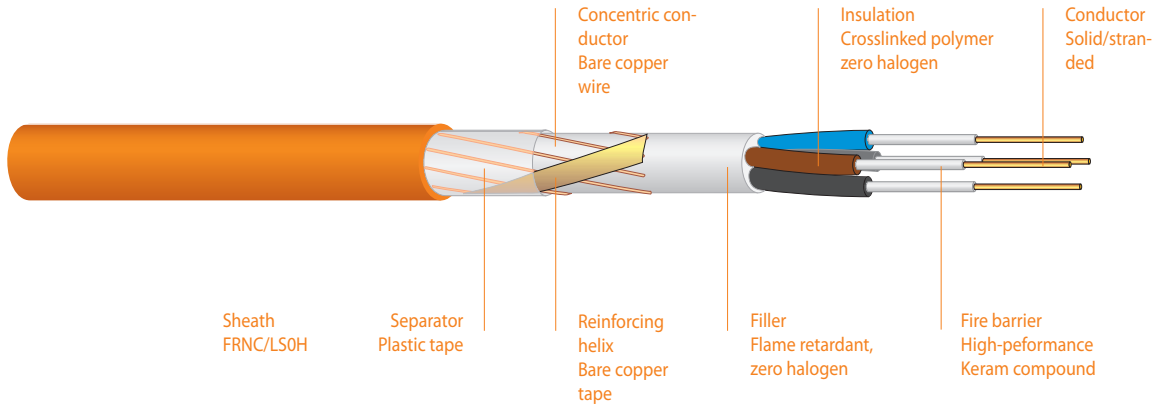

Product information

Application

Safety cables are used in all situations that require special protection against fire and flame damage for people and equipment and where a high degree of safety conditions must be fulfilled. Suitable for indoor applications. For outdoor applications, protection must be provided against exposure to direct sunlight. The cable should only be laid directly in earth or water if a protective conduit is used.

These cables correspond to the demands of system circuit integrity E90 in accordance with DIN 4102-12. System circuit integrity is guaranteed at an operating voltage up to 400V.

Permitted operating temperature at conductor +90°C.

Construction

Conductor	Bare copper, solid or stranded to IEC 60228, EN 60228, (VDE 0295)
Insulation	Double insulation, cross-linked, high-performance Keram special compound according to VDE 0266 "HXI1"
Filler	Halogenfree, compound or plastic tape
Concentric conductor	Bare copper wires with reinforced helix
Separator	Plastic tape
Outer sheath	Polyolefin compound in accordance to CENELEC HD 604 S1 and VDE 0276-604 "HM4"
Core colours	According to CENELEC HD 308 S2 and VDE 0293
Sheath colour	orange
Imprint	DAETWYLER PYROFIL KERAM (N)HXCH FE180 E90 1kV "N X MM2" VDE REG. NR. 7780 "VDS" "ORDER NO." "YEAR" "METRE MARKING"

Electrical Properties

Nominal voltage	0.6/1kV
Test voltage	4000V, 50Hz

General Properties

Minimum bending Radius	during and permanent installation	12 x D (multicore cable) (D = outer diameter)
Operating temperature	permanent installation	-45°C to +90°C
	during installation	-5°C to +50°C

- Zero halogen non corrosive gases
IEC 60754-2, EN 50267-2-2, VDE 0482-267-2-2
- Flame retardant
IEC 60332-1-2, EN 60332-1-2, VDE 0482-332-1-2
- Fire resistant (no flame propagation)
IEC 60332-3-22/-24 Cat. A/C, EN 50266-2-2/-4 Cat. A/C, VDE 0482-266-2-2/-4 Cat. A/C
- Minimum smoke emission
IEC 61034-1/-2, EN 61034-1/-2 (EN 50268-1/-2), VDE 0482-1034-1/-2 (VDE 0482-268-1/-2)
- Circuit integrity (FE180)
IEC 60331-11/-21 (180 minutes), VDE 0472 part 814, BS 6387 CWZ, IEC 60331-2, EN 50200, VDE 0482-200
- System Circuit integrity E90
DIN 4102 part 12
System Circuit integrity under effect of water
VdS 3423 [n x ≥ 16mm²]

Article No.	No. of cores x cross section n x mm ²	Cu content kg/km	Total weight app. kg/km	Mean overall diameter app. in mm
186 071	3 x 1,5 RE/1,5	66	248	13,2
186 195	3 x 2,5 RE/2,5	104	308	14,1
186 197	3 x 4 RE/4	161	404	15,7
187 278	3 x 6 RE/6	240	504	16,8
187 279	3 x 10 RE/10	408	727	18,6
187 251	3 x 16 RM/16	643	1166	24,4
187 406	3 x 25 RM/16	902	1496	25,8
172 417	3 x 35 RM/16	1190	1820	28,2
187 408	3 x 50 RM/25	1723	2493	32,5
187 409	3 x 70 RM/35	2410	3350	36,1
187 410	3 x 95 RM/50	3296	4570	42,0
187 411	3 x 120 RM/70	4236	5620	45,4
187 412	3 x 150 RM/70	5100	6850	50,7
187 413	3 x 185 RM/95	6383	8350	55,0
187 414	3 x 240 RM/120	8242	11100	62,1
186 072	4 x 1,5 RE/1,5	81	286	14,1
186 196	4 x 2,5 RE/2,5	128	358	15,1
186 198	4 x 4 RE/4	200	473	16,8
186 199	4 x 6 RE/6	297	621	18,1
186 200	4 x 10 RE/10	504	868	20,1
186 131	4 x 16 RM/16	796	1400	25,3
186 132	4 x 25 RM/16	1142	1895	28,9
186 133	4 x 35 RM/16	1526	2376	31,6
186 134	4 x 50 RM/25	2203	3249	36,7
186 135	4 x 70 RM/35	3082	4426	41,3
186 136	4 x 95 RM/50	4208	5809	46,4
186 137	4 x 120 RM/70	5388	7134	50,1
186 138	4 x 150 RM/70	6540	8703	55,3
186 139	4 x 185 RM/95	8159	10827	60,8
186 140	4 x 240 RM/120	10546	14139	69,2
186 073	7 x 1,5 RE/2,5	133	393	16,1
191 096	7 x 2,5 RE/2,5	200	491	17,3
187 415	12 x 1,5 RE/2,5	205	595	20,2
172 461	12 x 2,5 RE/4	334	798	22,6
187 402	24 x 1,5 RE/6	413	901	27,4
187 403	24 x 2,5 RE/10	696	1205	30,6
187 404	30 x 1,5 RE/6	499	1252	29,1
187 405	30 x 2,5 RE/10	840	1692	32,2

RE= circular, solid conductor

RM= circular, stranded conductor

Additional dimensions available on request.



Product information

Cable joint E30/E90

Application

For connection of two pyrofil® Keram cable types (N)HXH/(N)HXH CL/(N)HXCH FE180/E30-E60, (N)HXH/(N)HXCH FE180/E90.

The cable joint provides the relevant circuit integrity of the cables.

Goods supplied

Full shrink tube, without squeeze connections.

Construction

The joint consist of several heat-absorbing inner joints depending on the number of conductor connections and an external joint and several insulating tubes that act as a flame barrier.

Assembly

Cables are prepared as usual, with offset connection order. The connection joint is installed using any common warm air device.

Detailed assembly instructions are provided with each joint. Mandrel crimping is not permitted for crimped connections.

Article No.	Dimensions [n x mm²]				Description
1300 310	4 x	1,5	- 4 x	4	pyrosys® joint SMH4
1300 311	4 x	6	- 4 x	10	pyrosys® joint SMH4
1300 312	4 x	16	- 4 x	25	pyrosys® joint SMH4
1300 313	4 x	35	- 4 x	50	pyrosys® joint SMH4
1300 314	4 x	70	- 4 x	95	pyrosys® joint SMH4
1300 315	4 x	120	- 4 x	150	pyrosys® joint SMH4
1300 316	4 x	185	- 4 x	240	pyrosys® joint SMH4
1300 317	4 x	1,5/1,5	- 4 x	4/4	pyrosys® joint SMHC4
1300 318	4 x	6/6	- 4 x	10/10	pyrosys® joint SMHC4
1300 319	4 x	16/16	- 4 x	25/16	pyrosys® joint SMHC4
1300 320	4 x	35/16	- 4 x	50/25	pyrosys® joint SMHC4
1300 321	4 x	70/35	- 4 x	95/50	pyrosys® joint SMHC4
1300 322	4 x	120/70	- 4 x	150/70	pyrosys® joint SMHC4
1300 323	4 x	185/95	- 4 x	240/120	pyrosys® joint SMHC4



Multi cable support
E30-E90
Type Hermann clamp



Multi cable support
E30-E90
Type Hermann clamp S



Type SAS single clamp



Type SAS pre-assembled
single clamp
with fire protection
plugs type K6x5

Multi cable support E30-E90

Hermann clamp for wall and ceiling installation

Fixing distance ≤ 800 mm / ≤ 600 mm*

Application

For laying multiple cables on ceilings or walls. Circuit integrity is achieved for pyrofil® Keram cable types (N)HXH/(N)HXCH FE180/E30-E60, (N)HXH/(N)HXCH FE180/E90, JE-H(St)H FE180/E30-E90, JE-H(St)HRH FE180/E30-E90.

Goods supplied

Article No. 1300 964 and Article No. 1301 280
Set consists of 10 SHUD multi cable supports (Hermann clamps), including 10 pyrosys® fire protection plugs KDM, 30 mm. Drill bit and tool set supplied separately. Recommended drill bit SDS1, recommended tool set SWM-SM 50. Article No. 1301 240 Stainless steel plugs on request.

Technical Data

	Hermann clamp	Hermann clamp S
Material	Sendzimir galvanised sheet	Sendzimir galvanised sheet
Inner dimensions	app. 110 x 75 x 80mm	app. 70 x 52 x 56 mm
Outer dimensions	app. 125 x 95 x 80mm	app. 84 x 73 x 56 mm
Max. load	6 kg/m or 3 kg/m*	3 kg/m*
Fixing distance	≤ 800 or ≤ 600 mm*	≤ 800 or ≤ 600 mm*

Article No.	Clamp type	PU
1300 964	Hermann clamp	10 pieces
1300 346	Hermann clamp	750 pieces/skeleton box
1301 280	Hermann clamp S	10 pieces
1301 279	Hermann clamp S	1750 pieces/skeleton box
1301 240	Hermann clamp V2A(1.4301)	10 pieces

For quick assembly of the SHUD Hermann clamp we recommend the Pyrosys tool set SWM-SM 50.

*Please also see our optional installation methods: Installation of cable bundles in clamps, installation in steel armoured conduits, etc.

Single clamp

Type SAS

Fixing distance ≤ 600 mm

Application

For laying single and multiple cables on ceilings or walls. Circuit integrity is achieved for pyrofil® Keram cable types (N)HXH/(N)HXCH FE180/E30-E60, (N)HXH/(N)HXCH FE180/E90, JE-H(St)H FE180/E30-E90, JE-H(St)HRH FE180/E30-E90.

Article No.	Clamp type	Cable-Ø [mm]	PU
1300 016	SAS 6 D	5 - 6	100
1300 017	SAS 8 D	7 - 8	100
1300 018	SAS 10 D	9 - 10	100
1300 019	SAS 12 D	11 - 12	100
1300 020	SAS 14 D	13 - 14	100
1300 021	SAS 16 D	15 - 16	100
1300 022	SAS 18 D	17 - 18	100
1300 023	SAS 20 D	19 - 20	100
1300 024	SAS 22 D	21 - 22	100
1300 025	SAS 24 D	23 - 24	100
1300 026	SAS 26 D	25 - 26	100
1300 027	SAS 28 D	27 - 28	100
1300 028	SAS 30 D	29 - 30	100
1300 251	SAS 38 D neu	29 - 38	25
1300 252	SAS 47 D neu	38 - 47	20
1300 234	SAS 55 D neu	47 - 55	20
1300 250	SAS 60 D neu	55 - 60	20

To attach the single clamp, we recommend the use of Dätwyler pyrosys® fire protection plugs K6x5 and the Dätwyler pyrosys® tool set EWA 6x5 SM for quick assembly.

Type SAS pre-assembled single clamp with fire protection plugs type K6x5, 30 mm

1300 956	SAS 8 D - K6x5	7 - 8	100
1300 957	SAS 12 D - K6x5	11 - 12	100
1300 958	SAS 14 D - K6x5	13 - 14	100
1300 959	SAS 16 D - K6x5	15 - 16	100

Required tool set SMu 6 SM. The required SDS1 32 mm drillbit is included in the set.

Type SAS V4A steel grade 1.4571 (ask also for stainless steel plugs)

SAS 19 D - V4A	15 - 19	50
SAS 24 D - V4A	20 - 24	50
SAS 29 D - V4A	25 - 29	50
SAS 38 D - V4A	30 - 38	25
SAS 47 D - V4A	39 - 47	20
SAS 55 D - V4A	48 - 55	20
SAS 63 D - V4A	56 - 63	20

Please also see our optional installation methods: Installation of cable bundles in clamps, installation in steel armoured conduits, etc.

Strap clamp



Type B strap clamp without trough

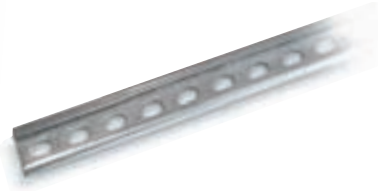

C-shaped rail 2970/2SLD



Type B strap clamp with trough

Product information

Strap clamp

Type B without trough (LW)

Fixing distance - 800 mm

Application

For laying several cables independently in parallel on ceilings and walls.

Circuit integrity is achieved for pyrofil® Keram cable types (N)HXH/(N)HXCH FE180/E30-E60, (N)HXH/(N)HXCH FE180/E90, JE-H(St)H FE180/E30-E90, JE-H(St)HRH FE180/E30-E90.

Article No.	Clamp type	Cable-Ø [mm]	PU
1300 043	B 12 D	6 - 12	100
1300 044	B 14 D	10 - 14	100
1300 045	B 16 D	12 - 16	100
1300 046	B 18 D	14 - 18	100
1300 047	B 22 D	18 - 22	100
1300 048	B 26 D	22 - 26	100
1300 049	B 30 D	26 - 30	100
1300 050	B 34 D	30 - 34	100
1300 051	B 38 D	34 - 38	100
1300 052	B 42 D	38 - 42	100
1300 053	B 46 D	42 - 46	100
1300 054	B 50 D	46 - 50	50
1300 055	B 54 D	50 - 54	50
1300 056	B 58 D	54 - 58	50
1300 057	B 64 D	58 - 64	50
1300 058	B 70 D	64 - 70	50
1300 059	B 76 D	70 - 76	50
1300 060	B 82 D	76 - 82	50
1300 061	B 90 D	82 - 90	50
1300 062	B 100 D	90 - 100	25
1300 063	B 110 D	100 - 110	25

The C-shaped rail 2970/2 SLD is required to fix the strap clamps.

Article No.	C-shaped rail	Slit width	PU
1300 064	2970/2 SLD	16 mm	on request

For assembly of the C-shaped rail, we recommend pyrosys® fire protection plugs KDM, 30 mm.

Do not exceed the maximum tensile force on the fire protection plugs! Shaped rails come in 2 m lengths. Other lengths are available on request.

For fast assembly of the shaped rail, we recommend the pyrosys® tool set SWM-SM.

Please also see our optional installation methods: Installation of cable bundles in clamps, installation in steel armoured conduits, etc.

Strap clamp

Type B with trough (LW)

Fixing distance ≤ 800 mm

Application

For laying several cables independently or in bundles in parallel on ceilings and walls. Circuit integrity is achieved for pyrofil® Keram cable types (N)HXH/(N)HXCH FE180/E30-E60, (N)HXH/(N)HXCH FE180/E90, JE-H(St)H FE180/E30-E90, JE-H(St)HRH FE180/E30-E90 (800 mm).

Article No.	Clamp type	Cable-Ø [mm]	PU
1300 045	B 16 D		100
1300 065	LW 16 D	8 - 13	100
1300 047	B 22 D		100
1300 066	LW 22 D	13 - 19	100
1300 048	B 26 D		100
1300 067	LW 26 D	19 - 23	100
1300 050	B 34 D		100
1300 068	LW 34 D	23 - 31	100
1300 051	B 38 D		100
1300 069	LW 38 D	31 - 36	100
1300 052	B 42 D		100
1300 070	LW 42 D	36 - 40	100
1300 053	B 46 D		100
1300 071	LW 46 D	40 - 43	100
1300 054	B 50 D		50
1300 072	LW 50 D	43 - 47	50
1300 055	B 54 D		50
1300 073	LW 54 D	47 - 51	50



Cable tray without threaded rod suspension

Application

For laying single and multiple cables under ceilings or on walls. Circuit integrity is achieved for pyrofil® Keram cable types (N)HXH/(N)HXCH FE180/E30-E60, (N)HXH/(N)HXCH FE180/E90, JE-H(St)H FE180/E30-E90, JE-H(St)HRH FE180/E30-E90. This cable tray system needs no threaded rod suspensions for circuit integrity.

Maximum permissible fixing distance up to 1500 mm.
Maximum load - 20 kg/m.

Technical Data

Material Steel galvanized
Nominal size 60 x 100 mm, 60 x 200 mm
60 x 300 mm, 60 x 400 mm

pyrosys® cable tray

Article No.	Type	Nominal size [mm]	PU
3800 032	RG 60-10S	100 mm	1 piece = 3 m
3800 033	RG 60-20S	200 mm	1 piece = 3 m
3800 034	RG 60-30S	300 mm	1 piece = 3 m
3800 035	RG 60-40S	400 mm	1 piece = 3 m

pyrosys® lateral connector

3800 036	60 RGV-BS 60S	60 mm	1 piece
----------	---------------	-------	---------

pyrosys® bottom connector

3800 038	VB-BS 10S	100 mm	1 piece
3800 039	VB-BS 20S	200 mm	1 piece
3800 044	VB-BS 30S	300 mm	1 piece
3800 045	VB-BS 40S	400 mm	1 piece

pyrosys® screws for fixing the tray on the console

3800 040	screw set KLAR	M6	100 piece
----------	----------------	----	-----------

pyrosys® lateral reinforcement in the area of consols

3800 041	ALS-BS S		1 piece
----------	----------	--	---------

pyrosys® plugs

Article No.	Type	Nominal size [mm]	PU
3800 077	M10x10 SD 10/10	M10x10	100 piece

pyrosys® wall consoles

3800 042	KWMS 010F	100 mm	1 piece
3800 043	KWMS 020F	200 mm	1 piece
3800 047	KWMS 030F	300 mm	1 piece
3800 048	KWMS 040F	400 mm	1 piece

pyrosys® consoles for hangers

3800 049	KUMS 010F	100 mm	1 piece
3800 050	KUMS 020F	200 mm	1 piece
3800 051	KUMS 030F	300 mm	1 piece
3800 053	KUMS 040F	400 mm	1 piece

pyrosys® hangers

3800 054	KDU 52-03F	300 mm	1 piece
3800 055	KDU 52-04F	400 mm	1 piece
3800 056	KDU 52-05F	500 mm	1 piece
3800 057	KDU 52-06F	600 mm	1 piece
3800 058	KDU 52-07F	700 mm	1 piece
3800 059	KDU 52-08F	800 mm	1 piece
3800 060	KDU 52-09F	900 mm	1 piece
3800 061	KDU 52-10F	1000 mm	1 piece

pyrosys® accessories to fix the consoles on hangers

3800 072	ring washer US 10x21	M10x21	100 piece
3800 073	nut SEM 10	M10	100 piece
3800 074	screw KLS 10x20	M10x20	100 piece

Wire mesh cable tray



Product information

Wire mesh cable tray

Application

For laying single and multiple cables under ceilings or on walls. Circuit integrity is achieved for pyrofil® Keram cable types (N)HXH/(N)HXCH FE180/E30-E60. Maximum permissible fixing distance up to 1250mm. Maximum load - 10 kg/m

Technical Data

Material	Steel wire, mesh 50x100mm, flange height 54mm, Galvanised (electrolytic)
Corrosion protection	in accordance with DIN 50961 (zinc layer 18-20 µ). Others on request
Approvals	VDE 0639, CEI 1537

pyrosys® wire mesh cable tray

Article No.	Type	Nominal width [mm]	kg/m	PU
1300 999	GR 54-100	100	1,29	3 m
1301 078	GR 54-150	150	1,53	3 m
1301 079	GR 54-200	200	1,77	3 m

Note: For cutting, a bolt cutter with "offset cutting" has to be used.

pyrosys® ceiling console screwless
Corrosion protection: Sendzimir galvanised DIN 17162 (zinc coating app. 21µ).
Other on request

Article No.	Type	Height x width [mm]	for	kg/piece	PU
1301 080	GR DKS 100	app. 210 x 230	GR 54-100	0,68	1
1301 081	GR DKS 150	app. 210 x 280	GR 54-150	0,75	1
1301 082	GR DKS 200	app. 210 x 380	GR 54-200	0,87	1

pyrosys® wall console, screwless
Corrosion protection: Sendzimir galvanised DIN 17162 (zinc coating app. 21µ).
Other on request

Article No.	Type	Height x width [mm]	for	kg/piece	PU
1301 083	GR WKS 100	app. 170 x 230	GR 54-100	0,46	1
1301 084	GR WKS 150	app. 170 x 280	GR 54-150	0,52	1
1301 085	GR WKS 200	app. 170 x 380	GR 54-200	0,64	1

Wire mesh cable tray Accessories

pyrosys® wire mesh cable tray accessories

Article No.	Type	Description	Info
1301 090	GR VBS	Push connector set	Contents: 50 push connectors, 50 Snap connectors, 200 bolts, nuts M6 snap-in parts
		for straight joints	For each push connection, 8 bolts, nuts, M6 snap-in parts, 2 push connectors and 2 snap connectors are provided.
		for 90° angles	For each 90° angle for barred groove 100, 6 bolts, nuts, snap-in-pieces M6 and 1.5 push connectors are provided For each 90° angle for barred groove 150, 8 bolts, nuts, snap-in-pieces M6 and 2 push connectors are provided For each 90° angle for barred groove 200, 6 bolts, nuts, M6 snap-in parts, 2 snap connectors and 1 push connector are provided
		for T-junctions	For each T-junction for a barred groove 100 or 200, 3 bolts, nuts, snap-in-parts M6 and snap connectors are provided
		for cross joints	For each T-junction for a barred groove 150 5 bolts, nuts, M6 snap-in parts, 1 snap connector and 2 push connectors are provided

pyrosys® wire mesh cable tray fixings

Article No.	Type	Description	Info
1301 096	GAS 8x220	Thread Suspension set M8x220	For thread attachment to ceiling console GR DKS Contents: 50 thread rails M8x220, KMU LF8 plugs 100 underlay disks, nuts M8 (recommended tool set SMu 8 SM, drillbit SDS2)
1301 097	GS 8x1000	Thread rod M8x1000	For thread attachment to wall console GR WKS; VPE 10 pieces
1301 098	GZS	Thread rod attachment Accessories	Accessories for thread rod suspension attachment GS 8x1000 Contents: 100 underlay disks M8 nuts, KMU LF8 plugs, (recommended tool set SMu 8 SM, drillbit SDS2)



K 6x5
30mm seat depth



KDM
30mm seat depth



KMu F10/KMu F12
40mm or 60mm seat depth

Fire protection plugs

Application

For installation of cable systems with integrated circuit integrity.

Note

The fire protection plugs are suitable for applications in concrete.

In order to guarantee the specified strength of the fire protection plugs, ensure that the drill holes are at the specified depth.

When using the drill bit supplied with the plug set, the hole depth is maintained.

pyrosys® Fire protection plugs

Article No.	Plug	Mounting of	Info
1300 953	Plug set K6x5 30 mm	pyrosys® SAS single clamps Single/distance clamps with M6 thread	Contains 200 K6x5 incl. SDS1 drill bit Required drill bit SDS1. This is included in the set. Recommended tool set EWA6x5 SM
1300 954	Plug set KDM 30 mm	Single/distance clamps with continuous hole 19-63 mm pyrosys® Hermann clamp	Contains 200 KDM incl. SDS1 drill bit Required drill bit SDS1. This is included in the set. Recommended tool set SWS-SM or SWS-SM 50.
1300 954	Plug set KDM 30 mm	Shaped rails pyrosys® 2970/2 SLD (for laying strap clamps)	Contains 200 KDM incl. SDS1 drill bit Required drill bit SDS1. This is included in the set. Recommended tool set SWS-SM
1300 005	Plugs KMUF10	Cable trays, cable ladders, M10 thread rod	Contains 50 KMUF10. Required drill bit SDS Duo-Set hv60 Recommended tool set SMu10H.
1300 006	Plugs KMUF12	Cable trays, cable ladders, M12 threaded rod	Contains 50 KMUF12. Required drill bit SDS Duo-Set hv60 Recommended tool set SMu12H.
1300 197	Plugs K6x80	Special mounting on insulated ceilings or walls with insulation thickness up to 75mm	Contains 150 K6x80 For use with standard drill bit. Min. required depth of 30mm to be guaranteed by the depth gauge on the drilling machine. Recommended tool set EWA 6x5 SM.
1300 448	Plugs K6x105	Special mounting on insulated ceilings or walls with insulation thickness up to 105mm	Contains 100 K6x110 For use with standard drill bit. Min. required depth of 30mm to be guaranteed by the depth gauge on the drilling machine. Recommended tool set EWA 6x5 SM.
1301 094	Plugs KMU LF8	tread rod M8	Contains 100 KMU LF8

Distribution box E30-E90

Type Hercules distribution box



Hercules distribution box E30-E90



Hercules-Cover
AHD E30-E90

Product information

Distribution box E30-E90

Type Hercules distribution box

Application

Terminal box or cover for power current and low current according to DIN 4102-12 (circuit integrity class E30 or E90). Emergency lighting, alarm circuits and fire announcement systems, fire alarm systems

Goods supplied

Hercules cover box E30-E90 Typ AHD...

To protect commercial distribution and branch boxes against the effects of fire for a period of 30 or 90 minutes (circuit integrity class E30 or E90). Emergency lighting, alarm circuits and fire announcement systems, fire alarm systems, protection of sub-distribution boxes, etc.

incl. mounting angles, screws, cartridge of fire protection filler SP S 100 SM-K

Hercules distribution box E30-E90 Typ HS...
(Power current distribution box) incl. mounting screws, cartridge of fire protection filler S 100 SM-K top hat rail 35x7,5x250 mm.

Hercules distribution box E30-E90 Typ HI...
(Low current distribution box) incl. mounting screws, cartridge of fire protection filler S 100 SM-K
QSA back mount frame ... x 105 x 50 mm.
(Quante: depth 30 mm, pitch: 27,5 mm)

Note

The Hercules distribution box or cover E30-E90 can be used for all pyrofil® Keram cable types (N)HXH/(N)HXCH FE 180/E30-E60, (N)HXH/(N)HXCH FE 180/E90, JE-H(ST)H FE180/E30-E90/ JE-H(ST)HRH FE180/E30-E90.

Function

Connections and branches of power current and low current. Please remember that due to the selectivity of safety circuits or in the case of a decrease in cross section, a corresponding circuit breaker must be installed.

Installation

The time required for assembly of the E30-E90 Hercules distribution box or cover is around 10 minutes. The screws are screwed into a predrilled hole without plugs. The cable inlets and outlets are sealed with the pyroplast S 100 SM-K fire protection filler. The cables do not need to be tied.

Article No.	Type	Dimensions [mm]	top hat rail / frame	PU
Hercules cover AHD E30-E90				
301 382	AHD 263013	outside 340 x 380 x 220	empty	1
	E90	inside 260 x 300 x 130	w / o base	

Hercules distribution box E30-E90 with top hat rail				
301 375	HS 263013	outside 340 x 380 x 220	35 x 7,5	1
	E90	inside 260 x 300 x 130	1-row	
301 376	HS 353013	outside 430 x 380 x 220	35 x 7,5	1
	E90	inside 350 x 300 x 130	2-rows	
301 377	HS 523013	outside 600 x 380 x 220	35 x 7,5	1
	E90	inside 520 x 300 x 130	3-rows	

Hercules distribution box E30-E90 with QSA trough				
301 378	HI 263013	outside 340 x 380 x 220	156 x 105 x 50	1
	E90	inside 260 x 300 x 130	(6 strips)	
301 379	HI 353013	outside 430 x 380 x 220	291 x 105 x 50	1
	E90	inside 350 x 300 x 130	(11 strips)	
301 380	HI 523013	outside 600 x 380 x 220	359 x 105 x 50	1
	E90	inside 520 x 300 x 130	(13 strips)	

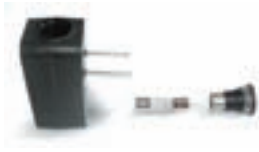

Fuse element for VAD 2



VAD E30 - E90



AD E30

Connection / terminal box E30-E90

Application

Connection / terminal box. Tested on the basis of DIN 4102-12, circuit integrity class E30.

Goods supplied

Halogen-free plastic box, cable glands, ceramic clamps, mounting rail and fire protection plugs.

Technical Data

Material Halogen-free special compound, fail-safe
Colour orange
Protection class IP 54

Accessories

Fuse element for VAD 2

Technical Data

AC 230V-Fuseholder 5 x 20 mm with 2A fuse.

Connection / terminal box VAD E30 – E90

Article No.	Type	Outer dimensions [mm]	Dimensions [mm ²]	PU
301 372	VAD 2 5x6 E30-E90	100 x 100 x 50	5 x 0,5-6	1
301 373	VAD 2 3x10 E30-E90	100 x 100 x 50	3 x 1,5-10	1

Accessories

Article No.	Description/ Accessorie	Dimensions [mm]	PU
660 301	AC 230V-Fuseholder 5 x 20 mm	40 x 20 x 20	1

Distribution box E30 AD E30

Application

Branch, connection or terminal box. Tested on the basis of DIN 4102-12, circuit integrity class E30.

Goods supplied

Mounting rail for feedthrough terminals, cable glands on request.

Function

Distribution box for emergency lighting or alarm systems. Connection box, eg. for smoke and heat extraction systems in damp areas (underground car parks, industry, etc.)

Technical Data

Material Halogen-free, fire resistant special compound
Systems test In accordance with DIN 4102-12 circuit integrity class E30
Wiring assembly on customers request
Cable inlets Available in various configurations
Colour Orange
Protection class IP 54

Distribution box AD E30

Article No.	Type	Outer dimensions [mm]	Dimensions [mm ²]	PU
on request	AD E30	130 x 130 x 108	2.5 - 6 mm ²	1
on request	AD E30	160 x 160 x 108	2.5 - 6 mm ²	1
on request	AD E30	200 x 200 x 108	2.5 - 6 mm ²	1
on request	AD E30	200 x 400 x 108 (twin-box, 6 inlets)	2.5 - 6 mm ²	1

Switzerland

Daetwyler Cables
Unit of Daetwyler Switzerland Inc.
Gotthardstrasse 31
CH-6460 Altdorf
T +41-41-875 12 68
F +41-41-875 19 86
info.ch@daetwyler-cables.com
www.daetwyler-cables.com

Germany

Dätwyler Cables GmbH
Lilienthalstraße 17
DE-85399 Hallbergmoos
T +49-811-99 86 33 0
F +49-811-99 86 33 30
info.de@daetwyler-cables.com
www.daetwyler-cables.com

Dätwyler Cables GmbH
Auf der Roos 4-12
DE-65795 Hattersheim
T +49-6190-88 80 0
F +49-6190-88 80 80
info.de@daetwyler-cables.com
www.daetwyler-cables.com

Austria

Dätwyler Cables GmbH
Office Austria
Tenschertstraße 8
AT-1230 Wien
T +43-1-810 16 41 0
F +43-1-810 16 41 35
info.at@daetwyler-cables.com
www.daetwyler-cables.com

Great Britain

Datwyler (UK) Ltd
Unit B
Omega Enterprise Park
Electron Way
Chandlers Ford
GB-Hampshire SO53 4SE
T +44-2380-279 999
F +44-2380-279 998
info.uk@daetwyler-cables.com
www.daetwyler-cables.com

China

Datwyler Cables+Systems
(Shanghai) Co. Ltd
Building 16, No. 1-111,
Kang Qiao Dong Road
Kang Qiao Industrial Zone, Pudong
CN-201319 Shanghai, P.R. China
T +86-21-6813 0066
F +86-21-6813 0298
info@datwyler-china.com
www.datwyler-china.com

Datwyler (Suzhou)
Cabling Systems Co. Ltd
Block 31, 15# Dong Fu Road
Suzhou Singapore Industrial Park
CN-215123 Suzhou, P.R. China
T +86-512-6265 3600
F +86-512-6265 3650
sales.harnessing@datwyler-china.com
www.datwyler-china.com

Singapore

Datwyler (Thelma)
Cables+Systems Pte Ltd
29 Tech Park Crescent
SG-638103 Singapore
T +65-6863 1166
F +65-6897 8885
sales@datwyler.com.sg
www.daetwyler-cables.com